

OVER  
**50**  
YEARS  
*of success*

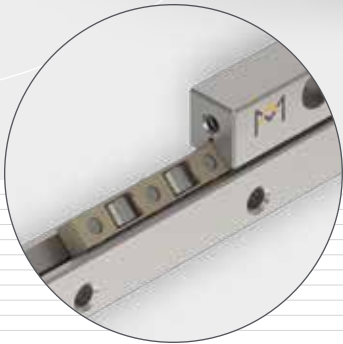

## **LINEAR BEARING TYPE RSDE-ACC WITH ANTI CAGE CREEP TECHNOLOGY**

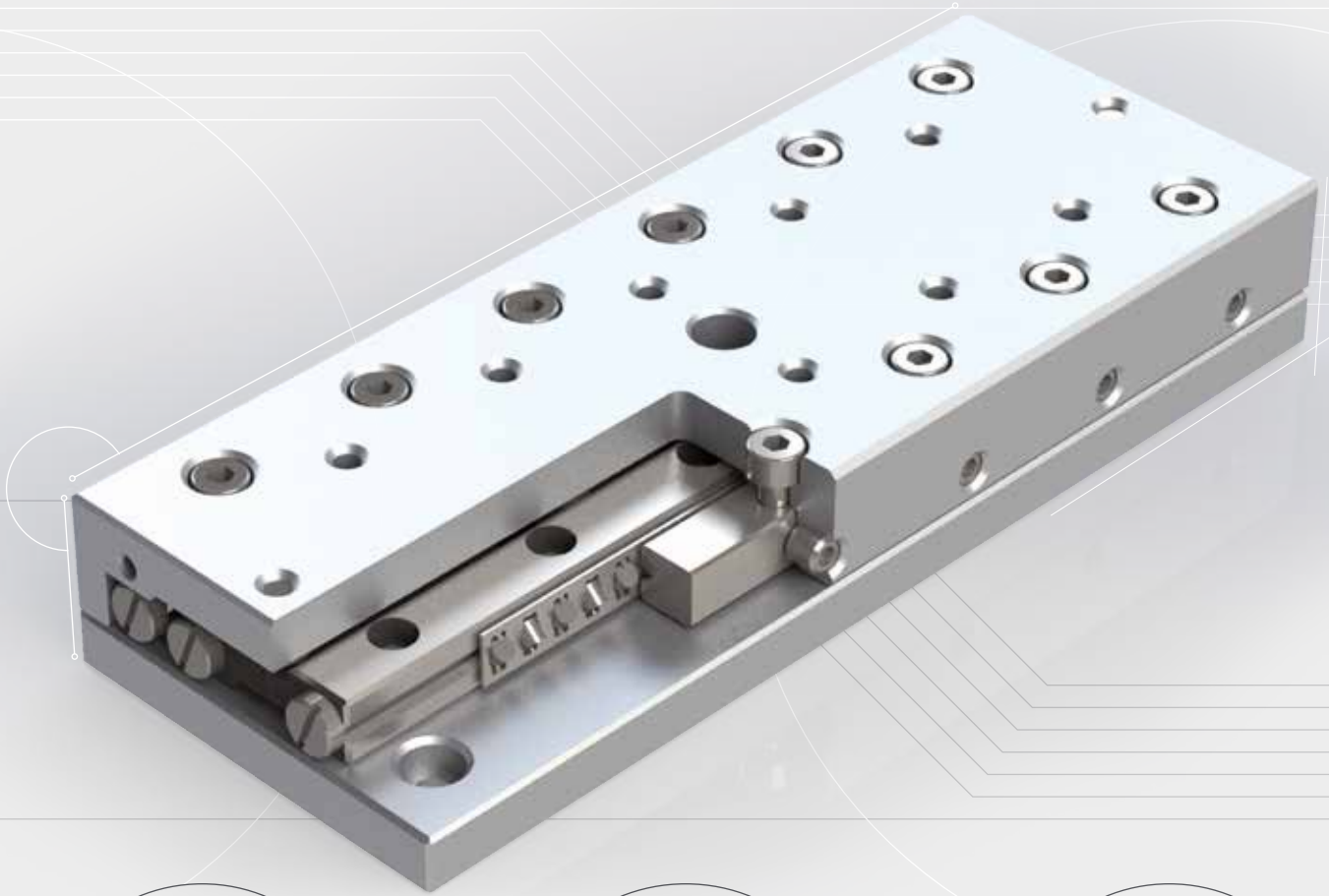

## Company's headquarters in Dedemsvaart, Netherlands



Innovative design and manufacture of precision linear bearings, frictionless slides, positioning stages and engineered-to-spec motion systems.





# INTRODUCTION

*PM has engineered and manufactured innovative and top quality precision linear bearings and slides at our research and production facilities in the Netherlands since 1966. We are experts in finding solutions that meet the specific requirements of a wide variety of industry applications. A trusted partner for hundreds of industry heavyweights around the globe, our client base ranges from the semiconductor industry, medical technology and metrology sectors, to industrial automation, space and defence industries.*

## COMPANY

The key to the exceptional quality of PM products lies in our highly specialised manufacturing machinery and facilities. Specifically, the PM production facility is temperature controlled and built to suppress and minimise distortions caused by vibration. Our precision rails are produced with remodeled, non-standard machinery. The resulting high quality of our products makes PM an attractive supplier for various high-tech industries including semiconductor, optical and life sciences.

## NEW PRODUCTS

We constantly deploy the latest technologies to create new products or functionally enhance existing products in our range. Clients typically choose to work with PM for our proven ability to meet a complex set of requirements, mostly including maximum performance of parts in the most compact of spaces. We are always working to further refine the performance of PM products, in order to ensure that we consistently meet the requirements of clients in high-tech industries. The following new PM products are the result of our relentless drive to be operating at the cutting edge of the latest technologies:

- **Linear bearing type RNG:** is a compact design with high load capacity. Available with optional Anti Cage Creep solution (ACC). Perfectly integrates robustness and compactness.
- **Micro roller slide type PMMR:** featuring crossed-rollers. Designed for best performance in micro-sized applications.
- **Flat Mounted Bearing type FMB:** is an extremely flat, low-friction and easy to install table bearing.

## CUSTOMISED PARTS

In addition to offering high-quality standardised products, we design and manufacture engineered linear bearings and positioning systems meeting our clients' application-specific requirements.

PM combines the latest knowledge from its in-house R&D department, developments in manufacturing technology

more widely as well as performance insights generated by industry deployment of precision applications.

Over the past 50 years PM has expanded its reach to serve a global client base. Our experienced, multilingual engineering and sales teams stand ready to work with you in realising your demanding projects.

Technical data in this catalogue is based on standard quality grade Q8 (no suffix). For higher quality grades please contact our product experts to discuss your requirements.

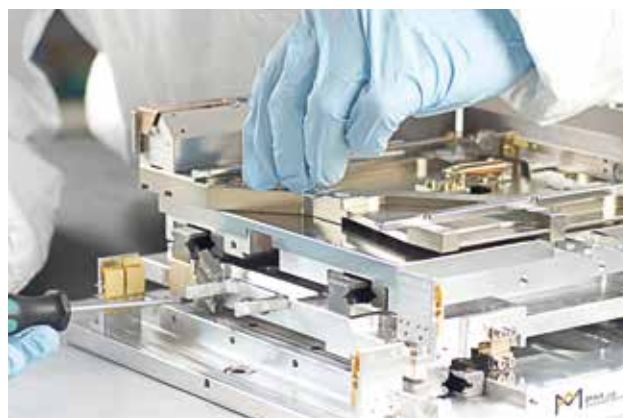

## DISCLAIMER

*This catalogue is the result of a full revision of its previous edition. It reflects the latest progress in linear bearings technology as well as insights gathered from industry application. Any information from previous editions that does not correspond to the data in this current edition, is therefore invalid. Due to the continuous development of our product range, we reserve the right to make modifications without prior notice.*

© Copyright October 2020, second edition  
PM B.V. - Discover Precision

Reproduction in part or in whole is only allowed with written authorization of PM.



# PRODUCT OVERVIEW

PM linear bearings are used as components in multiple industries worldwide. What really sets apart PM products is their unsurpassed quality and technical performance in terms of accuracy, their extremely low levels of friction, high rigidity and long lifetime.

Our wide range of linear bearings allows for maximum design flexibility, realising a play-free linear movement that is both cost-effective and the best fit for its application. Popular linear bearings are also available as set packages including all the essential components like cages, end pieces and attachment screws. In the following pages, this catalogue presents these standard sets, specifying options for load capacity and stroke length.

Importantly, PM customers benefit from over 50 years' experience in the field of linear bearings manufacturing. As a result of our continuous testing of innovations and new insights in engineering and manufacturing, our linear bearings are constantly being optimised further and often become an industry benchmark.

At PM we are always driven by our goal to be industry leaders in quality and performance. We possess the expertise and manufacturing capability to supply custom made linear bearings and linear slides.

So whether you choose a standard product as presented in this catalogue or a customised component that meets your specific needs, we only ever deliver top quality.

## 1. LINEAR BEARING TYPE RSD

- Equipped with balls or rollers
- For light up to medium load
- Available in size 1.5 - 24 mm
- Lengths from 20 - 1400 mm
- Also available as a set, see page 41



## 2. LINEAR BEARING TYPE RSDE

- Equipped with rollers, size 3 – 9 mm
- For precision applications
- For medium up to high loads
- Anti cage creep technology optional
- Also available as a set, see page 57



## 3. LINEAR BEARING TYPE RNG

- Equipped with rollers 4 and 6 mm
- Very compact design and high load ratings
- Offers reduced weight
- Anti cage creep technology optional
- Also available as a set, page 67

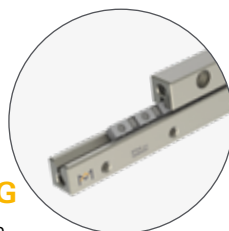

## 4. LINEAR BEARINGS TYPE N/O AND M/V

- Equipped with needle rollers
- Best load ratings and maximum rigidity
- Lengths from 100 - 1200 mm
- Anti cage creep technology optional

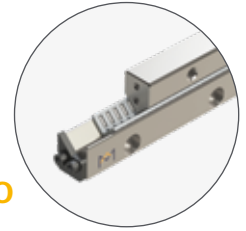

## 5. DOUBLE PRISM TYPE DS

- Compact design
- Can be combined with RSD linear bearings and recirculating units UK and UR
- Available in size 2 - 15 mm
- Lengths up to 1400 mm

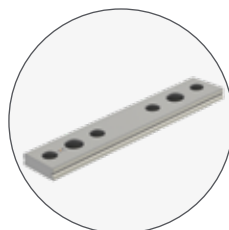

## 6. RECIRCULATING UNITS TYPE UK AND UR

- For unlimited travel
- Low profile and space saving design
- Equipped with balls (UK) or rollers (UR)
- Available in size 2 - 15 mm

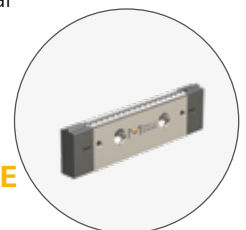



# ASSEMBLY PROCEDURE

## PRIOR TO ASSEMBLY

PM linear bearings are precision components; they have to be handled with meticulous care. To achieve a perfect linear bearing, it is necessary to respect the following guidelines:

- When handling the components. Damage on the rail surface will impact the running performance and operational lifetime
- Prevent contact with any foreign materials when mounting the rails
- During assembly, ensure that all linear bearing components have the same temperature
- For uniform tightening of the bolts the use of a torque screw driver is recommended. Various models are available.

## ASSEMBLY LINEAR BEARINGS

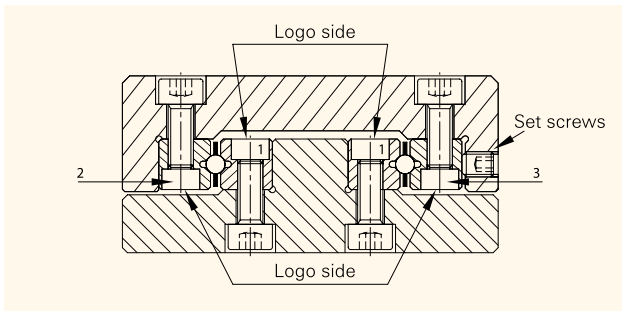

For satisfactory installation of all types of linear bearings in this catalogue, it is necessary to consider the following points:

- 1) To determine the location of fixing holes in the support structure (slide base) the holes in the rails should be taken as a reference and "copied" onto the support structure. This is highly desirable as the original pitch of individual holes may have altered during hardening by as much as 0.4 mm. To compensate this, special type GD or GDN attachment screws can be supplied. The dimensions of these screws are listed in the tables at the end of each chapter.
- 2) Carefully de-burr and clean all elements, to ensure a flat surface and a perfect fit of the rails.
- 3) Now, as a required first step, to fasten the inner rail pair (marked as 1 in figure above) the base and reference face 1 of the linear bearing rails should be lightly oiled before they are clamped against the mounting and reference shoulder. Subsequently,

they can be fastened by starting from one end and working towards the opposite end.

- 4) Parallelism of the V-groove of the rails (A and B) should be checked to ensure they don't exceed the tolerance of the linear bearings (page 14). After these steps have been followed, the slide element is ready for assembly.

Parallelism of rails V-groove:  $\Delta A$  and  $\Delta B$

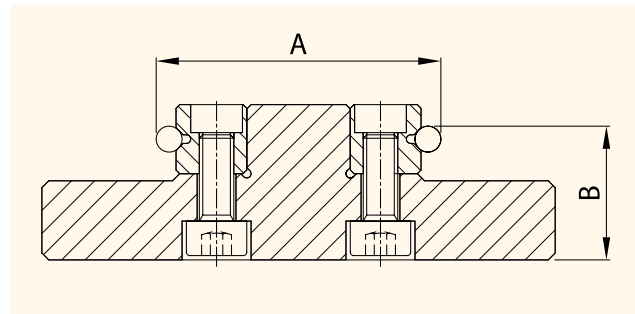

- 4.1) The fixed bearing rail (2) should be mounted as described under step 3 above, but care should be taken not to tighten the adjustable rail (marked as 3 in figure on the left side) too much, so as to leave a gap between the V-grooves for the insertion of ball cages, roller cages or needle cages.
- 5) If any end stop screws are present, remove them now.
- 6) Carefully insert the cages. When placed in their exact position, lightly secure the adjustable rail until the screws are finger-tight.
- 7) Fit the end screws or end pieces.
- 8 I) The linear bearing set is now ready to be backlash free-adjusted using the lateral preload set screws (page 19, Preload Settings). The amount of preload is given in the tables at page 23.
- 8 II) Before starting the preload procedure carefully move the slide top over its stroke length back and forth and feel that there are no irregularities.
- 9) Preload procedure: put the slide on a clean surface on its side with the lateral preload set screws up. Follow step 1, 2 and 3 for the correct preload sequence.
  - Step 1. Start in the middle position and adjust the set screws with the recommended torque value, working outwards from the middle. Notice: Only adjust the screws directly above the cage.



Step 2. Move the slide top in one direction and adjust the set screws to the recommended torque value.

Step 3. Move the slide top in opposite position and repeat the adjusting for the screws which are now above the cages.

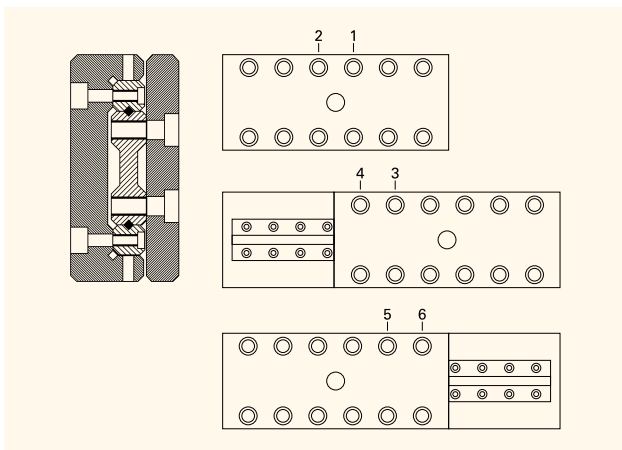

Again move the slide top back and forth a couple of times and feel that there are no irregularities.

- 10) Secure the attachment screws on the adjusting rail.
- 11) When assembly is complete, the linear bearings must be checked for absence of play and inspected for running quality.



# TABLES

## RECOMMENDED PRELOAD SETTINGS

Table 1 Linear bearings type RSD with roller cages

Roller size (mm)	Pitch cage (mm)	Set screw	Pitch* (mm)	Preload (Ncm)
1.5	3	M2.5	10	0.75
2	4	M3	15	1.50
3	5	M5	25	4.50
4	7	M5	40	11.50
6	9	M6	100	27.50
9	14	M8	100	105.50
12	18	M10	100	212.00
15	20	M12	100	370.00

Table 5 Linear bearings type N/O and M/V with needle cages

Needle size (mm)	Pitch cage (mm)	Set screw	Pitch* (mm)	Preload (Ncm)
2	4.5	M6	50	1.05
2	4.5	M8	100	1.30
2.5	5	M8	100	2.70
2.5	5.5	M8	100	2.90
3	6	M12	100	5.70
3.5	7	M14	100	7.70

\*pitch between the preload setscrews

Table 2 Linear bearings type RSD with ball cages

Ball size (mm)	Pitch cage (mm)	Set screw	Pitch* (mm)	Preload (Ncm)
1.5	3	M2.5	10	0.15
2	4	M3	15	0.36
3	5	M5	25	1.05
4	7	M5	40	2.70
6	9	M6	50	4.00
9	14	M8	100	11.70
12	18	M10	100	25.00
15	20	M12	100	34.50

Table 3 Linear bearings type RSDE with roller cages

Roller size (mm)	Pitch cage (mm)	Set screw	Pitch* (mm)	Preload (Ncm)
3	3.3	M5	25	16
4	4.4	M5	40	41
6	6.6	M6	50	86
9	On request			

Table 4 Linear bearings type RNG with roller cages

Roller size (mm)	Pitch cage (mm)	Set screw	Pitch* (mm)	Preload (Ncm)
4	4.4	M3	25	14
6	6.6	M4	25	25



# ANTI CAGE CREEP TECHNOLOGY

PM Anti Cage Creep (ACC) technology reduces cage creep down to zero.

With high acceleration up to 15g, the design is compact and cost-effective.



ACC is integrated in a crossed roller bearing design. Available also for stainless steel designs with an ECM-machined (Electro-Chemical Machining) integrated rack (ACCI all metal design) and UHV-compatibility.



A robust brass rack is locked in place inside the V-groove.



In its integrated form, anti cage creep (ACCI) is ECM-machined and available for stainless steel rails and selected rail types only.

## THE PROBLEM: CAGE CREEP

In the push for faster production times, machine designers are constantly aiming for higher process speed, reduced size and weight of the design, while simultaneously requiring the highest possible machine travel and positioning accuracy.

Cage creep can occur in non-recirculating linear bearings applications where vibrations, improper mounting, very high acceleration and de-acceleration, inadequate tolerances on the mounting surfaces, uneven preloading or moment loading are present.

As the cage creeps out of its original position, increased friction, reduced travel length and premature wear of the linear bearings occur. This shortens the lifetime and can result in premature failures.

## OUR SOLUTION: ANTI CAGE CREEP (ACC)

PM engineers have further enhanced the ACC technology making it suitable for high-tech and extremely dynamic applications. For decades, our ACC solution has proven its superior ability to prevent cage creep when applied in the most demanding applications and operating in the most challenging conditions. The ACC system is integrated in the design of the linear bearing without influencing the external boundary or mounting dimensions. This allows for direct replacement of bearings in under-performing applications with the ACC solution.

### PROVEN RECORD OF RESULTS

- No increase in friction
- No reduction in accuracy
- No adverse influence from lubrication
- Operational lifetime extended to its limit
- Zero cage creeping
- Works with all mounting applications
- Easy to assemble





The ACC system is the best performing and most cost-effective solution you will find on the market. Currently our precision rails with optional ACC are available to order with the RSDE and RNG series, in all accuracy grades.

**FRICTION FORCE**

The ACC solution is the result of a very careful design and manufacturing process. The graph below illustrates the resulting fact that the force to be applied to overcome friction remains virtually unchanged.

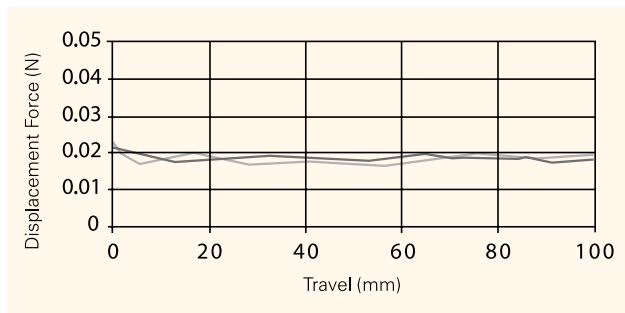

**APPLICATIONS**

The ACC solution is well suited for the high speed, high precision demands of the electronics and semiconductor industry, for applications such as wire bonding stages and pick-and-place units.

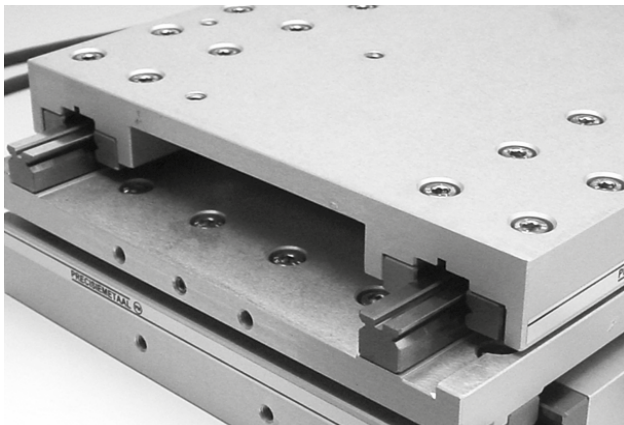

**OPERATING TEMPERATURE**

Linear bearings with ACC solution are capable of operating in temperatures between -40 °C and +80 °C. This gives ACC a significant advantage over similar systems using plastic components.

**ACCELERATION**

Max. acceleration 150 m/s<sup>2</sup> (15g)

**ONE ACC SET INCLUDES**

A standard linear bearing set with ACC solution consists of:

- 4 pcs. rail type RSDE-ACC
- 2 pcs. roller cages type KRE(V)-ACC (rollers retained)

No end screws are required

**Leading global manufacturers have chosen the ACC solution as the best solution against cage creep on the market.**

**Optional:**

End screws type GA and attachment screws type GD.

The following products are available with anti cage creep technology:

- Linear bearing sets RSDE
- Linear bearing sets RNG
- Miniature slides MSR

**LINEAR BEARING SETS WITH ACC**  
 Type RSDE-ACC, see from page 90 onwards.  
 Compact type RNG-ACC, see from page 94 onwards



*Layout of ACC*

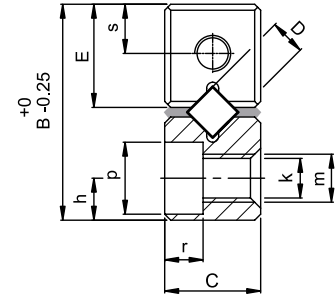
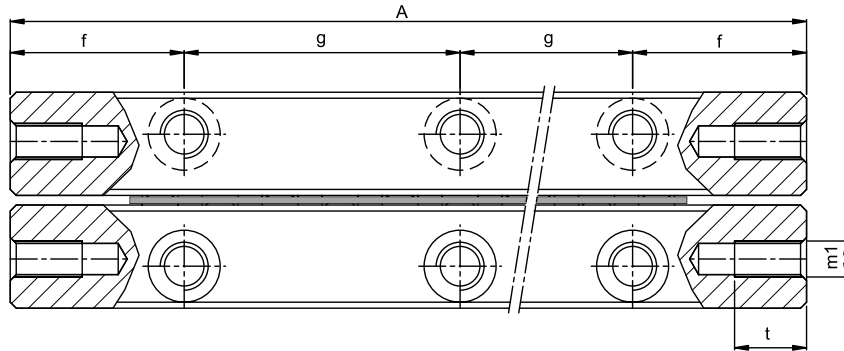

One set consists of: 4 rails + 2 roller cages, both with ACC optional

RSDE-ACC Kit	Main dimensions					Mounting holes							End pieces		
	A	B	C	E	D	f	g	h	k	m	p	r	m1	s	t
<b>RSDE-3050x8KRE-ACC</b>	50						1x25								
<b>RSDE-3075x12KRE-ACC</b>	75						2x25								
<b>RSDE-3100x18KRE-ACC</b>	100						3x25								
<b>RSDE-3125x22KRE-ACC</b>	125						4x25								
<b>RSDE-3150x28KRE-ACC</b>	150						5x25								
<b>RSDE-3175x34KRE-ACC</b>	175	18	8	8.6	3	12.5	6x25	3.5 <sup>+0.2</sup>	3.2	M4	6	3.2	M3	4.1	5.5
<b>RSDE-3200x40KRE-ACC</b>	200						7x25								
<b>RSDE-3225x46KRE-ACC</b>	225						8x25								
<b>RSDE-3250x52KRE-ACC</b>	250						9x25								
<b>RSDE-3275x54KRE-ACC</b>	275						10x25								
RSDE-3300x60KRE-ACC	300						11x25								
RSDE-4080x10KRE-ACC	80						1x40								
RSDE-4120x16KRE-ACC	120						2x40								
RSDE-4160x22KRE-ACC	160						3x40								
RSDE-4200x28KRE-ACC	200						4x40								
RSDE-4240x36KRE-ACC	240	22	11	10.6	4	20	5x40	4.5 <sup>+0.2</sup>	4.3	M5	7.5	4.1	M3	5	7
RSDE-4280x42KRE-ACC	280						6x40								
RSDE-4320x48KRE-ACC	320						7x40								
RSDE-4360x54KRE-ACC	360						8x40								
RSDE-4400x60KRE-ACC	400						9x40								

**Bold** = Short lead time item

Regular = Long lead time item - please ask us about prices and lead times

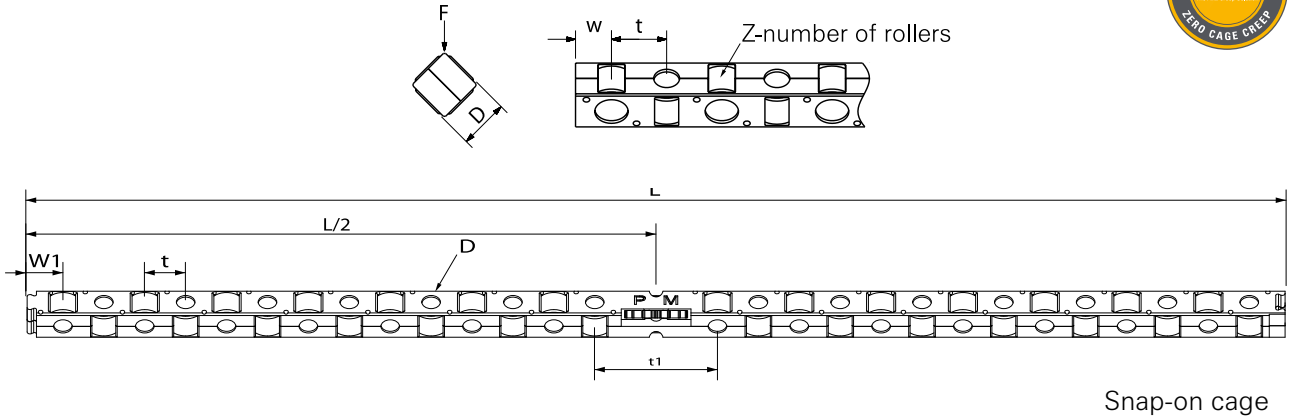

Weight (g)	C <sub>dyn</sub> in (N)	Roller cage							Stroke	Type
		D	t	t <sub>1</sub>	w	w <sub>1</sub>	Z	L		
116	3136						8	35.1	25	RSDE-3050x8KRE-ACC
161	4704						12	48.3	50	RSDE-3075x12KRE-ACC
210	7056						18	68.1	60	RSDE-3100x18KRE-ACC
259	2744						22	81.3	85	RSDE-3125x22KRE-ACC
310	10976	3	3.3	10.9	2.2	2.95	28	101.1	95	RSDE-3150x28KRE-ACC
365	13328						34	124.6	100	RSDE-3175x34KRE-ACC
405	15680						40	144.4	110	RSDE-3200x40KRE-ACC
457	18032						46	164.2	120	RSDE-3225x46KRE-ACC
507	20384						52	184	130	RSDE-3250x52KRE-ACC
555	21168						54	190.6	160	RSDE-3275x54KRE-ACC
605	23520						60	210.4	175	RSDE-3300x60KRE-ACC
317	7850						10	54	50	RSDE-4080x10KRE-ACC
475	12560						16	80.4	75	RSDE-4120x16KRE-ACC
630	17270						22	106.8	100	RSDE-4160x22KRE-ACC
788	21980						28	133.2	120	RSDE-4200x28KRE-ACC
945	28260	4	4.4	13.2	2.8	3.85	36	173	130	RSDE-4240x36KRE-ACC
1112	32970						42	199.4	160	RSDE-4280x42KRE-ACC
1259	37680						48	225.8	185	RSDE-4320x48KRE-ACC
1416	42390						54	252.8	210	RSDE-4360x54KRE-ACC
1573	47100						60	278.6	240	RSDE-4400x60KRE-ACC

F = For load direction please refer to picture provided

Units: mm

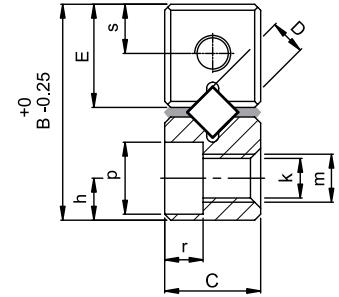
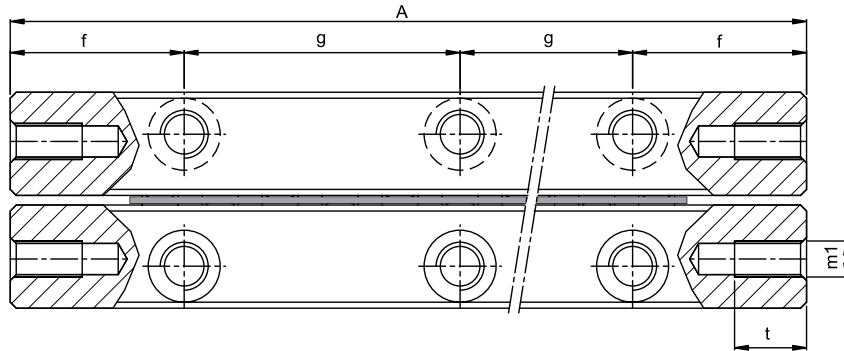

One set consists of: 4 rails + 2 roller cages, both with ACC optional

RSDE-ACC Kit	Main dimensions					Mounting holes							End holes		
	A	B	C	E	D	f	g	h	k	m	p	r	m1	s	t
RSDE-6100x8KRE-ACC	100						1x50								
RSDE-6150x14KRE-ACC	150						2x50								
RSDE-6200x16KRE-ACC	200						3x50								
RSDE-6250x22KRE-ACC	250						4x50								
RSDE-6300x28KRE-ACC	300	31	15	14.9	6	25	5x50	6 <sup>±0.2</sup>	5.2	M6	9.5	5.2	M5	7	8.5
RSDE-6350x32KRE-ACC	350						6x50								
RSDE-6400x38KRE-ACC	400						7x50								
RSDE-6450x44KRE-ACC	450						8x50								
RSDE-6500x48KRE-ACC	500						9x50								

**Bold** = Short lead time item

Regular = Long lead time item - please ask us about prices and lead times

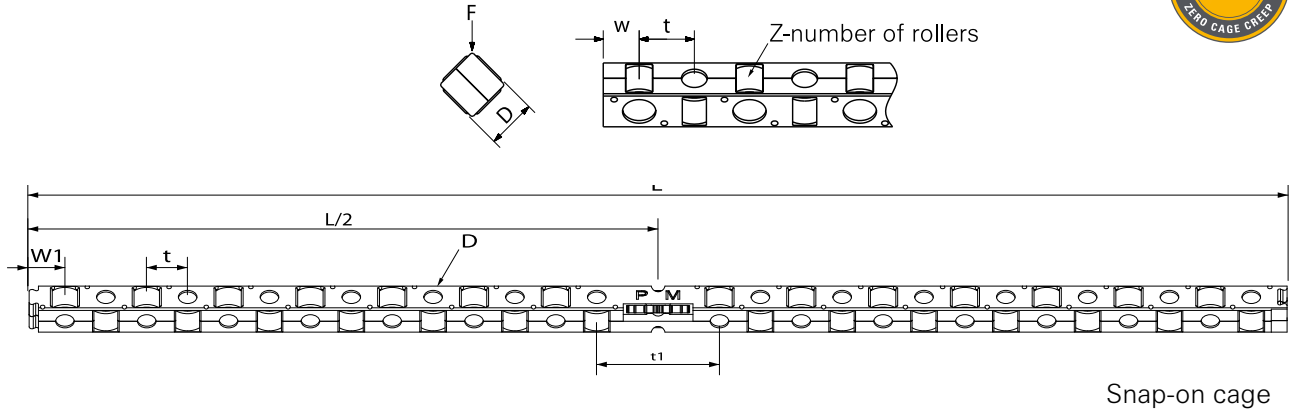

Weight (g)	C <sub>dyn</sub> in (N)	Roller cage							Stroke	Type
		D	t	t1	w	w1	Z	L		
650	14120						8	68	60	RSDE-6100x8KRE-ACC
968	24710						14	107.6	80	RSDE-6150x14KRE-ACC
1291	28240						16	120.8	150	RSDE-6200x16KRE-ACC
1610	38830						22	160.4	170	RSDE-6250x22KRE-ACC
1936	49448	6	6.7	19.8	4.3	6.3	28	200	200	RSDE-6300x28KRE-ACC
2254	56480						32	234.4	230	RSDE-6350x32KRE-ACC
2578	67070						38	274	250	RSDE-6400x38KRE-ACC
2910	77660						44	313.6	270	RSDE-6450x44KRE-ACC
3218	84720						48	340	310	RSDE-6500x48KRE-ACC

F = For load direction please refer to picture provided

Units: mm



## SAVE TIME!

Direct access to the 3D CAD models of our standard products

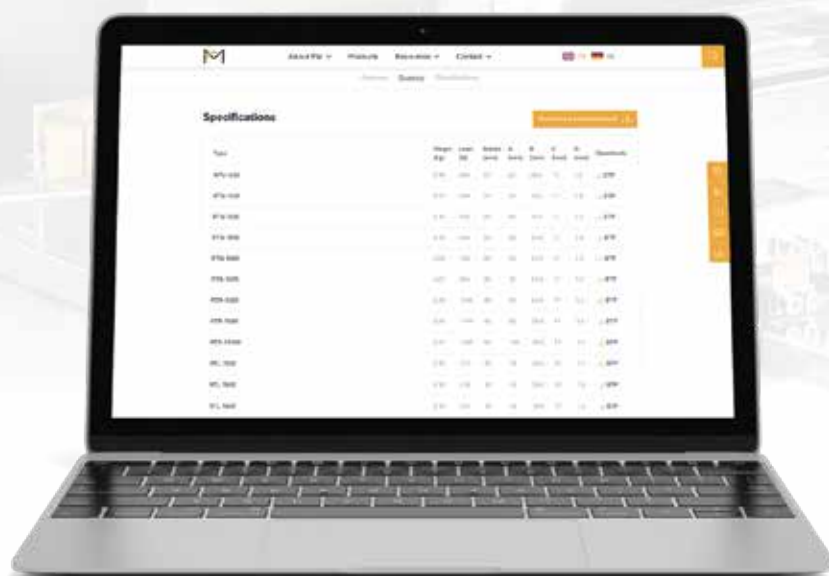

[www.PM.NL](http://www.PM.NL)

# PM RESEARCH AND PRODUCTION FACILITIES



## PM B.V.

Galileistraat 2  
NL-7701 SK, Dedemsvaart  
The Netherlands

Tel: +31 523 61 22 58  
info@PM.nl

[www.PM.nl](http://www.PM.nl)

2020