



## TECHNICAL DATA

### ASSEMBLY

For each type the mounting holes are drilled to standard configuration in the slide top and slide base facilitating quick and easy installation into the application. Threaded holes in the slide parts are according to ISO-standards. Please note that dimensions listed in this catalogue are in mm.

PM linear slides are precision devices; proper mounting is a prerequisite for their performance according to specifications. Slides must be mounted onto rigid, fine-machined (preferably fine-milled or grinded), flat surfaces and must be supported over their entire base length. Specifications as listed are only valid when these conditions are met.

The surface of the side opposite to the preload set screws is ground parallel to the slide axis and can therefore be used as a reference face for mounting the slide into the application.

### OPERATING TEMPERATURE

PM slides are capable of operating in a temperature range of -30 °C to +120 °C. For slides which contain plastic components (plastic cages), the operating temperature range is -30 °C to +80 °C.

### MAXIMUM VELOCITY AND ACCELERATION

#### RTN / RTL, RTNG and RTS types crossed roller slides

Max. recommended speed  $v = 60$  m/min.

Max. acceleration  $a = 50$  m/sec<sup>2</sup>.

#### PMM type ball micro slides

Max. recommended speed  $v = 60$  m/min.

Max. acceleration  $a = 50$  m/sec<sup>2</sup>.

#### PMMR type crossed roller micro slides

Max. recommended speed  $v = 120$  m/min.

Max. acceleration  $a = 200$  m/sec<sup>2</sup> (20g).

### DELIVERED CONDITION

PM slides are ready-to-use. The slides are factory preloaded by the use of lateral set screws and free of play. The amount of preload is approximately 10% of the dynamic load capacity. The slides are delivered with a small quantity of oil for lubrication which also protects the rails in the slides against corrosion. The quality grade of the crossed roller linear bearings which are used in the linear slides is in standard accuracy grade Q8.

The slides are free from stick-slip. The coefficient of friction range for slides fitted with balls or cylindrical rollers is 0.0005 to 0.003. PM slides are manufactured according the best manufacturing standards, offering high smoothness and precision of movement.

PMM and PMMR type of micro slides are factory preloaded by means of geometry pairing.

### SERVICE

PM slides are factory-preloaded and don't need readjustment. Depending on the application requirements the linear bearings need re-lubrication. There are no specific calculations to determine the lubrication intervals for linear bearings, thus it must be determined for each application. However, we recommend a small quantity of lubrication at least twice a year for oil and at least once a year for grease.

The lubrication can be applied to the linear bearings using the lateral gap between the rails. If this is not possible cause of the design of the machine we advise the use of special lubrication holes which can be added to the rails. If this is the case for you, please consult a PM advisor.

### STORAGE

PM slides are precision components and need to be handled with great care. Slides are delivered in a package, special developed for optimum protection against external vibrations and contamination. For transport and storage use the original package. Slides should be stored at constant room temperature and under clean and dry conditions. Remove the slides from their packaging just before use.

### LOADS AND MOMENTS

Slides listed in this catalogue are able to carry loads and moments in any direction. Load ratings are compliant with ISO and DIN standards for calculating roller bearings (ISO standard 281, for miniature slide type PMM DIN 636, part 3). To ensure high running accuracy and to prevent the occurrence of play, any vibration and overloading must be avoided.

Load capacity  $C$ , defined in ISO76-1987, is the maximum downward load or force located in the center of the upper part in horizontal zero-position.

$M_I$  = Pitch moment: when a load is cantilevered (not symmetrically mounted) off the end of a slide, parallel to the direction of travel.

$M_d$  = Roll moment: when a load is cantilevered off the side of a slide, perpendicular to the direction of travel.

$M_r$  = Yaw moment: when a force causes a rotation moment around the centre of an axis.

Exceeding of the listed moment ratings may reduce the lifetime of the bearings and can degrade accuracy. Please feel free to contact one of our product specialists for information.

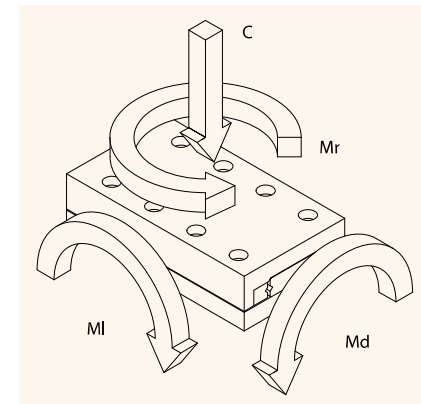

### VACUUM AND CLEANROOM COMPATIBLE SLIDES

The majority of PM slides can be prepared for use in (ultra-high) vacuum or cleanroom environments. Special care has to be taken, for example when selecting low outgassing materials, special lubricants, surface finishings, vented stainless steel fasteners for use in blind tapped holes, special ball- or crossed roller cages as well as switches and wires. Slides are assembled in our modern cleanroom cells certified to ISO/FDIS 14644-1 class 6 with cleanspots class 5.

With over 50 years' experience we are well equipped and capable to fulfil your orders meeting even the most demanding requirements.

Please consult your PM advisor for more information.

