

Model Code and Basic Performance Specifications

WP	C	-	35	-	50	-	CN	-	**
<p>* Specifications: Input shaft diameter, etc.</p> <p>Code: CN, CF, SN, SNH, SNJ</p> <p>Ratio: 50, 80, 100, 120</p> <p>Size: 35, 42, 50, 63, 80</p>									
<p>C: Component type S: Simple unit type U: Unit type</p>									
<p>Type</p>									
<p>Model name: WP series</p>									

Frame Size

Size/Ratio	1/50	1/80	1/100	1/120
35				
42				
50				
63				
80				

Reducer Specifications

Size	Ratio	Nominal Output Torque *1	Maximum Output Torque *2	Emergency Stop Torque *3	Nominal Input Speed *4	Maximum Input Speed *5	Permitted Axial Load *6
		Nm	Nm	Nm	r/min	r/min	×10-4kgm ²
35	50	7	23	46	3000	8500	0.027
	80	9	27	55			
	100	9	32	63			
42	50	21	44	91	3000	7300	0.055
	80	26	50	102			
	100	28	63	129			
	120	28	63	129			
50	50	33	73	127	3000	6500	0.158
	80	40	86	149			
	100	47	96	172			
	120	47	96	172			
63	50	51	127	242	3000	5600	0.385
	80	66	142	266			
	100	70	163	295			
	120	70	163	295			
80	50	89	253	447	3000	4800	1.03
	80	122	316	590			
	100	142	346	673			
	120	142	346	673			

*1) The maximum value allowable at the input rotation speed of 2000r/min

*2) The maximum torque when starting and stopping

*3) The maximum torque when it receives shock

*4) The maximum average input speed

*5) The maximum average input torque

*6) Values depend on the input shaft diameter, etc.

Closed Style - Component Sub-assembly

WPC-□-□-CN

WPC-□-□-CF

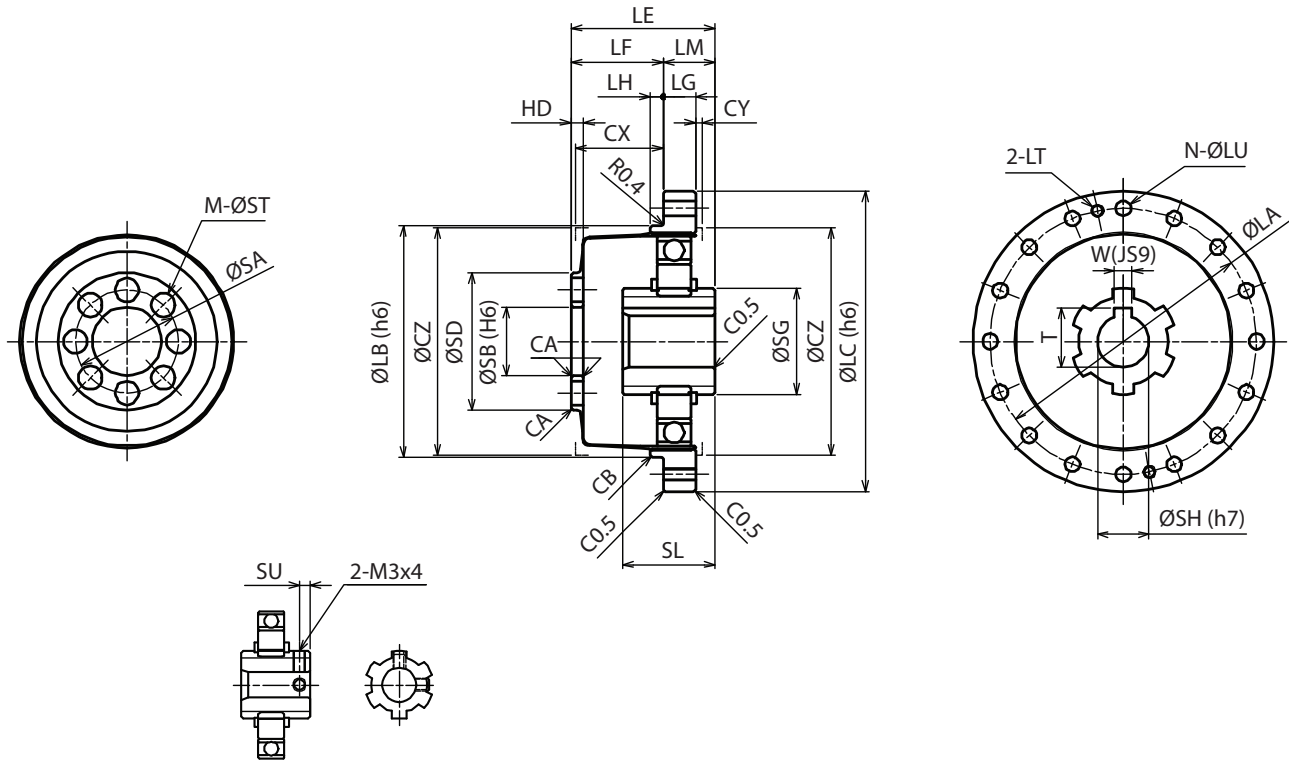

INPUT SHAFT FOR 35 & 42

Size	LA	LB	LC	N*1	LU	LT	LE	LF	LG	LH	LM	SG	SH	SL	W
35	44	38	50	8 (6)	3.5	M3	28.5	17.5	6	2	11	15.8	6	18.5	-
42	54	48	60	16 (12)	3.5	M3	32.5	20	6.5	2.5	12.5	15.8	8	20.7	-
50	62	54	70	16 (12)	3.5	M3	33.5	21.5	7.5	3	12	24.8	12	21.5	4
63	75	67	85	16 (12)	4.5	M4	37	24	10	3	13	27.8	14	21.6	5
80	100	90	110	16 (12)	5.5	M5	44	28	14	3	16	27.8	14	23.6	5

Size	T	SU	SA	SB	SD	M	ST	HD	CA	CB	CX	CY	CZ
35	-	2.5	17	11	23.5	6	4.5	2.4	C0.5	C0.3	17	1	38
42	-	3	19	10	27	6	5.5	3	C0.5	C0.3	19	1	45
50	13.8	-	24	16	32	8	5.5	3	C0.5	C0.5	20.5	1.5	53
63	16.3	-	30	20	40	8	6.5	3	C0.5	C0.5	23	1.5	66
80	16.3	-	40	26	52	8	8.8	3.2	C0.5	C0.5	26.8	1.5	86

*1) -CN and -CF are different in dimensions. The -CF value is shown in parentheses

*2) For details in the input section, check the drawings