

Rotary drum  
VTMF  
Assembly instructions

Version 1.1  
2022-11-08

## Table of contents

<b>1</b>	<b>About these instructions .....</b>	<b>3</b>
1.1	Purpose .....	3
1.2	Contact information .....	3
1.3	Product designation .....	3
1.4	Symbols .....	4
<b>2</b>	<b>Safety .....</b>	<b>5</b>
2.1	Safety instructions .....	5
2.2	Warnings .....	5
2.3	Requirements for personnel .....	7
2.4	Personal protective equipment .....	7
2.5	Requirements for incorporation into a complete machine .....	7
<b>3</b>	<b>Product description .....</b>	<b>8</b>
3.1	Intended use .....	8
3.2	Technical data .....	8
3.3	Product overview .....	11
<b>4</b>	<b>Transport .....</b>	<b>14</b>
4.1	Transport with slings .....	15
<b>5</b>	<b>Assembly .....</b>	<b>16</b>
5.1	Attaching the VTMF1010 .....	17
5.2	VTMF2010 attachment .....	22
5.3	VTMF3010 attachment .....	27
<b>6</b>	<b>Operation .....</b>	<b>29</b>
6.1	Operating modes .....	29
<b>7</b>	<b>Maintenance .....</b>	<b>30</b>
7.1	Maintenance tasks .....	30
7.2	Lubricating .....	32
<b>8</b>	<b>Troubleshooting .....</b>	<b>33</b>
<b>9</b>	<b>Disposal .....</b>	<b>34</b>
<b>10</b>	<b>Spare and wear parts .....</b>	<b>35</b>
<b>11</b>	<b>Annexes .....</b>	<b>36</b>
11.1	Content of the declaration of incorporation .....	36

## 1 About these instructions

### 1.1 Purpose

The purpose of these assembly instructions is to provide users with all the information necessary for proper and safe installation of the rotary drum in a complete machine.

### 1.2 Contact information

TAKTOMAT GmbH

Rudolf-Diesel-Straße 14  
86554 Pöttmes

Tel.: +49 (0) 8253-9965-0  
Fax: +49 (0) 8253-9965-50  
E-mail: [info@taktomat.de](mailto:info@taktomat.de)  
Internet: <http://www.taktomat.de/>

### 1.3 Product designation

**Product designation:** Rotary drum

**Product type:** VTMF

## 1.4 Symbols

The following symbols are used in these instructions:

### **Instructions and directions**

Requirements for performing an instruction are indicated by a check mark.

The action steps to be executed are numbered.

The results of individual action steps are indicated by a black arrow. The overall result of an instruction is marked by a white arrow in a black circle.

### **Example**

- ✓ Requirement
  - 1. Instruction (step 1)
  - 2. Instruction (step 2)
    - ⇒ Result or response of system to step 2
  - 3. Instruction (step 3)
    - ➡ Overall result of the instruction

### **Enumerations**

Enumerations in no strict order are indicated as follows:

- Property A
  - Detail 1
  - Detail 2
- Property B
  - Detail 1
  - Detail 2

## 2 Safety

### 2.1 Safety instructions

#### General safety instructions

- Read through these instructions completely
- Observe the information and instructions in these instructions
- Keep unauthorized persons away from the working area
- Work on electrical systems may only be carried out by qualified electricians
- Keep the instructions in a safe place and make them available to all employees
- Observe the documentation of the supplier components

### 2.2 Warnings

#### 2.2.1 Structure of the warnings

All the warnings in these instructions have the following structure:

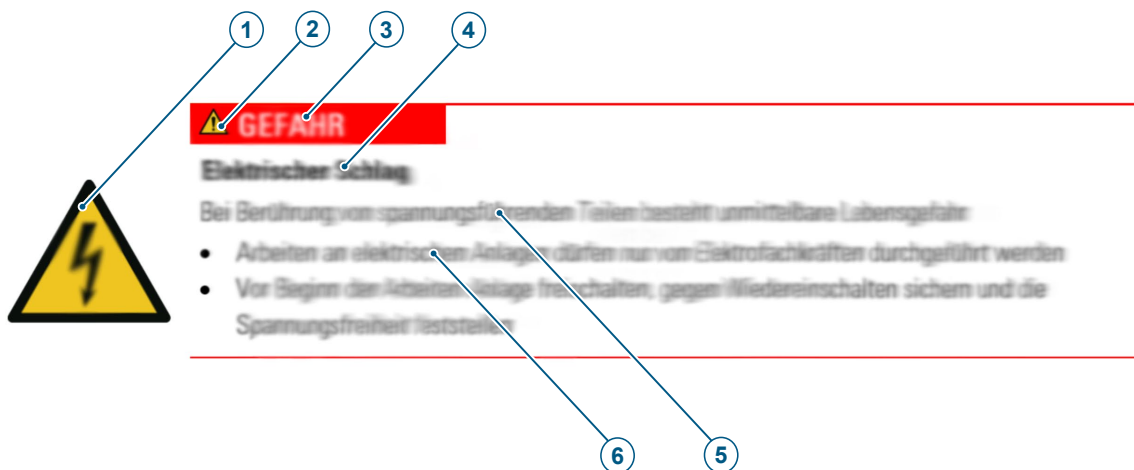

Fig. 1: Structure of the warnings

1	Hazard-specific symbol	2	Hazard symbol
3	Signal word	4	Type and source of danger
5	Possible consequences of non-observance	6	Procedure for hazard prevention

### 2.2.2 Meaning of the signal words and symbols

The following signal words are used in this document:

Signal word	Meaning
DANGER	Indicates a hazardous situation which will result in death or serious injury.
WARNING	Indicates a potentially hazardous situation which may result in death or serious injury.
CAUTION	Indicates a potentially hazardous situation which may result in minor or moderate injury.
NOTICE	Indicates a potentially hazardous situation which may result in property and environmental damage.

The following symbols for dangers, warnings, mandatory requirements and prohibitions are used in this document:



General warning sign



Warning: Suspended load



Wear head protection



Wear eye protection



Wear foot protection



Wear hand protection

### 2.3 Requirements for personnel

The activities described in these instructions may only be performed by qualified personnel.

Qualified personnel are persons who are able to carry out the work assigned to them due to their technical training, knowledge and experience. They are familiar with the relevant standards and regulations and are able to recognize potential hazards on their own.

### 2.4 Personal protective equipment

Personal protective equipment is used to protect personnel from impairments to safety and health during work. Personnel must wear the personal protective equipment when performing all of the activities described in these instructions. The required personal protective equipment is indicated in the different chapters of these instructions.

### 2.5 Requirements for incorporation into a complete machine

The rotary drum is partly completed machinery. Operation of the rotary drum is only permitted in a complete, CE-compliant machine or system.

The manufacturer of the complete machinery or system is responsible for integrating the rotary drum into the system in such a way that completely safe operation is guaranteed.

- During operation, it is prohibited to remain in the immediate vicinity of the rotary drum. Staying in the vicinity of the rotary drum is only permitted within the scope of inspection tasks, maintenance or servicing work by specially trained personnel.
- Maintenance work must be carried out in accordance with the maintenance plan and the operating instructions.
- All tasks on or at the rotary drum may only be carried out by trained, qualified personnel.

### 3 Product description

#### 3.1 Intended use

The rotary drum is designed for incorporation in CE-compliant complete machinery or an overall system. The rotary drum turns and tilts loads about the horizontal rotary axis. To this end, customer attachments can be mounted on the rotary indexer.

The optional integrated maintenance locking is used to prevent accidental or unauthorised machine movements.

All applications deviating from this intended use are not permitted.

- Modifications must be approved by TAKTOMAT
- Die rotary drum may only be operated within the defined operating parameters
- Use of the rotary drum in the food sector is not permitted

#### 3.2 Technical data

##### 3.2.1 Operating conditions

Application range	indoors/in enclosed spaces: the installation room must be dry, clean and low-vibration
Temperature range [°C]	+10 to +40
Relative humidity [%]	40 to 70
Media	do not expose to aggressive media

##### 3.2.2 Storage conditions

Application range	indoors
Temperature range [°C]	-22 to +50
Relative humidity [%]	40 to 70
Media	do not expose to aggressive media
Storage period > 6 months	provide additional corrosion protection



### 3.2.3 Dimensions

#### VTMF1010

Output flange Ø [mm]	380
Axis height [mm]	240
Internal diameter Ø [mm]	165
Centring Ø [mm]	210
Weight without drive and options [kg]	~120
Standard graduations	14
Direction of rotation	clockwise, counterclockwise, oscillating
Installation position	vertical

#### Model accuracies

For absolute positioning in angular seconds* ["]	±6
For relative positioning in angular seconds ["]	±40
Axial runout on the output flange Ø [mm]	0.02
True running on the drive flange Ø [mm]	0.02

*\*If using the complete TAKTOMAT control package*

#### Step-down ratio

Step-down ration, internal	14
----------------------------	----

The performance data of the complete drive are included in the machine card.

#### VTMF2010

Output flange Ø [mm]	560
Axle height [mm]	398
Internal diameter Ø [mm]	190
Centring device Ø [mm]	242 H7
242 H7 weight without drive or options [kg]	~360
Standard partitions	14
Direction of rotation	clockwise, counterclockwise, oscillating
Installation position	Vertical

**Model precisions**

For absolute positioning in arc seconds *["]	±6
For relative positioning in arc seconds ["]	±40
Axial run-out on output flange Ø [mm]	0.02
Radial run-out on output flange Ø [mm]	0.02

*\*When using the complete control package from TAKTOMAT*

**Transmission**

Internal gear reduction	14
-------------------------	----

The technical data for the complete drive are included on the machine card.

3.3 Product overview

**VTMF 1010 construction**

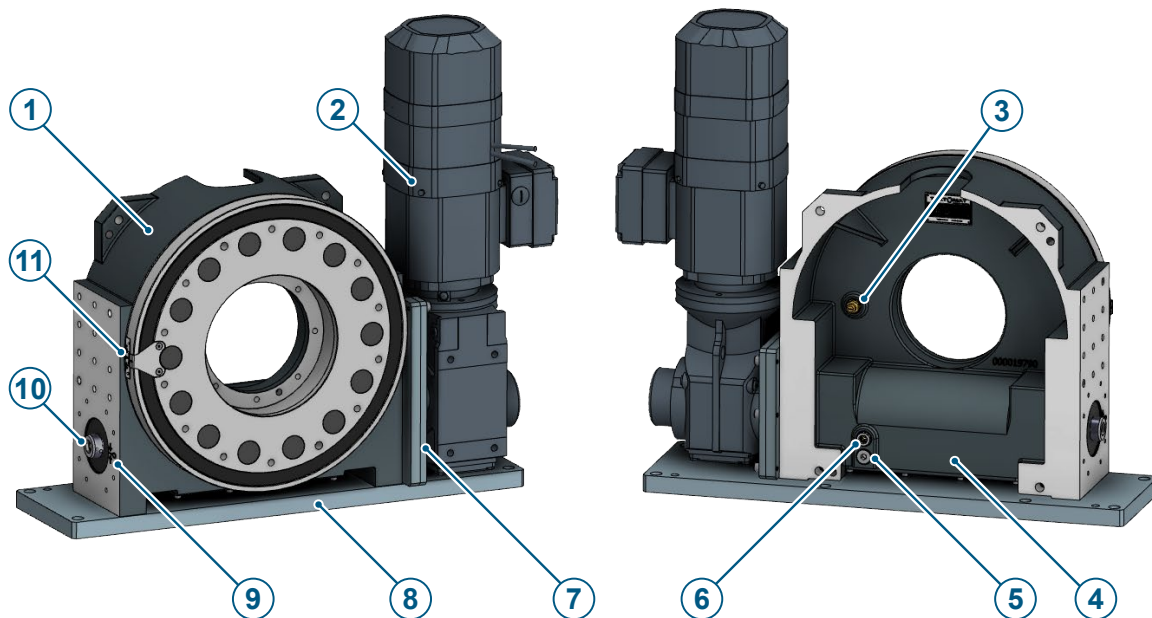

Fig. 2: VTMF 1010 construction

1	Rotary drum	2	Drive
3	Air valve	4	Housing
5	Oil drain plug	6	Oil sight glass
7	Drive flange (optional)	8	Mounting plate
9	Position indicator	10	Input shaft (drive)
11	Vernier		

**VTMF 2010 construction**

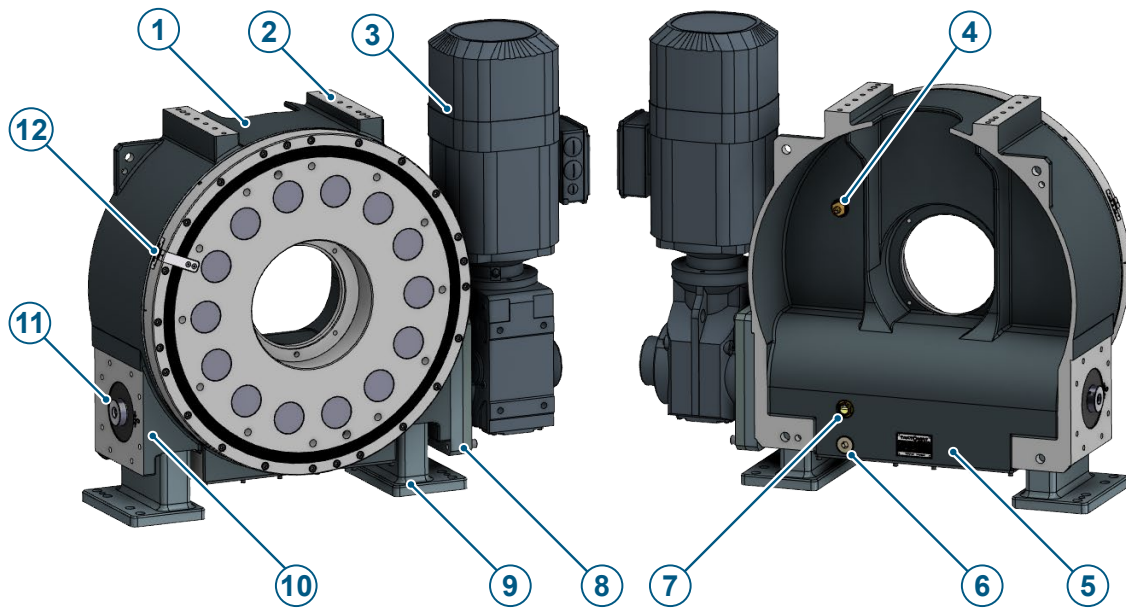

Fig. 3: VTMF 2010 construction

1	Rotary drum	2	Mount for maintenance disconnecter
3	Drive	4	Air valve
5	Housing	6	Oil drain plug
7	Oil sight glass	8	Drive flange (optional)
9	Housing base	10	Position indicator
11	Input shaft (drive)	12	Vernier

**VTMF 3010 construction**

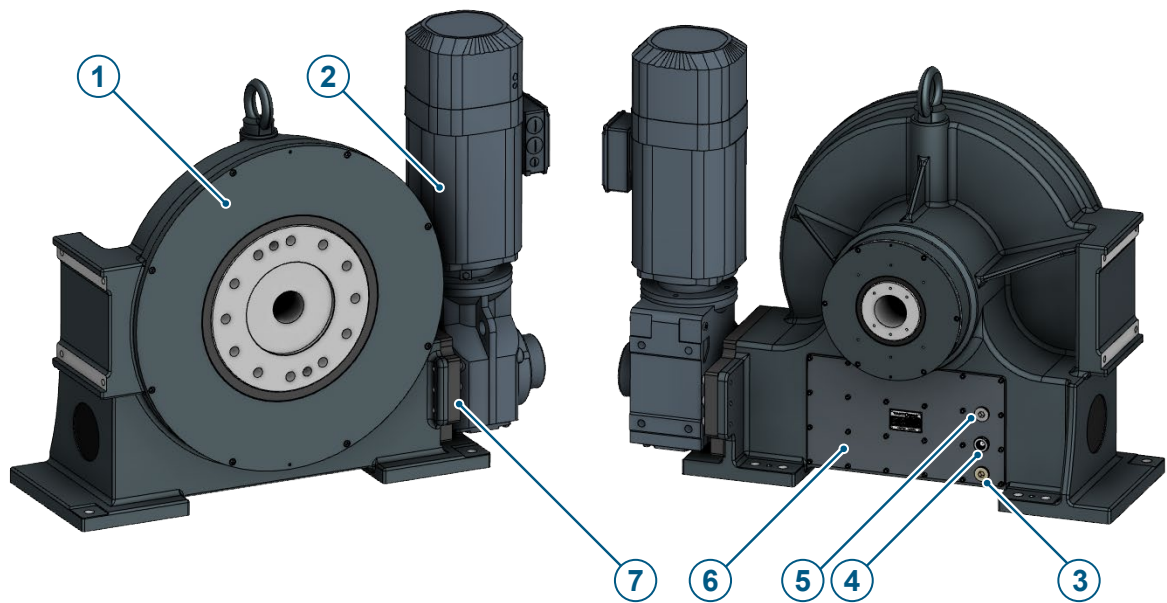

Fig. 4: VTMF 3010 construction

1	Rotary drum	2	Drive (optional)
3	Oil drain plug	4	Oil sight glass
5	Air valve	6	Housing
7	Drive flange (optional)		

## 4 Transport

Required personal protective equipment



### **WARNING**

#### **Tipping or falling loads**



Suspended loads can tip or fall down. This can cause serious or fatal injuries to persons.

- Do not step under suspended loads
- Keep unauthorized persons out of the danger zone
- Observe the weight and centre of gravity
- Only use suitable, approved and undamaged load handling attachments

### **NOTICE**



#### **Damage to components**

Improper transport can cause material damage

- Carry out transport carefully and note the symbols on the packaging
- Align the lifting eyes in the direction of the load
- Follow the operating instructions for the lifting gear

Check the delivery immediately on receipt for transport damage and to make sure it is complete.

In the event of externally visible transport damage, observe the following:

- Do not accept the delivery or accept it only with reservations
- Note the extent of the damage on the transport documents or on the transport delivery note
- Report material damage to the manufacturer immediately

#### 4.1 Transport with slings

Attach the slings to the attachment points as shown below, and make sure they are functioning properly.

The angle between the vertical and the chain sling or sling strap must be between 0 and 45°.

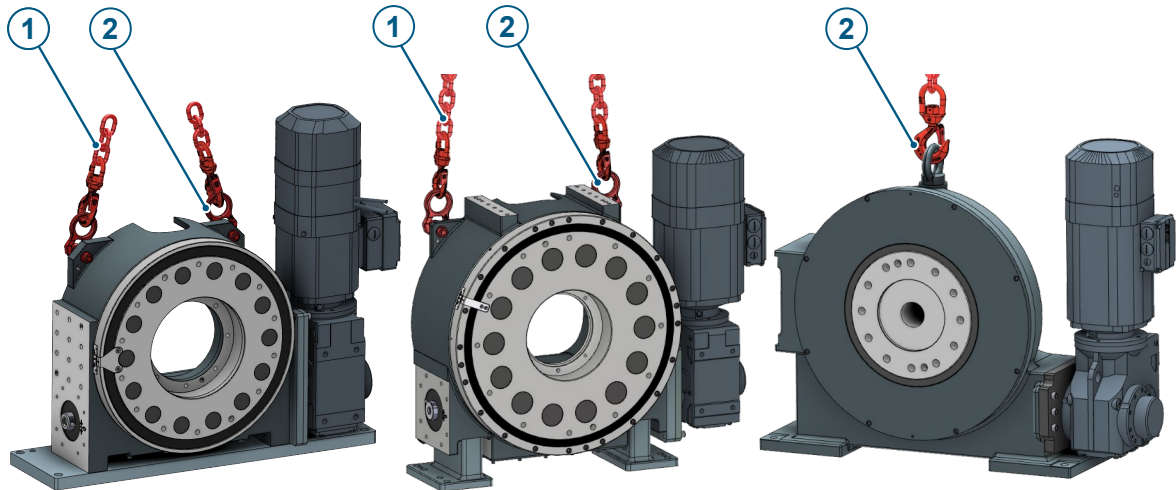

Fig. 5: Lifting instructions, attachment points and slings; left: VTMF 1010-2010; right: VTMF3010

1	Sling chain	2	Sling
---	-------------	---	-------

#### Screw connection points thread table

For the rotary drum type VTMF, the slings are equipped with the appropriate thread. Refer to the dimension sheet on the TAKTOMAT website for thread sizes.

#### Recommended slings

Type	Quantity	Sling	Screw size
VTMF1010	2	VLBG 1t	M12
VTMF2010	2	VLBG 1.5t	M16
VTMF3010	1	Eye bolt DIN 580	M30 × 45

## 5 Assembly

Required personal protective equipment



### NOTICE

#### Damage to components



Improper attachment of the drive can cause material damage

- The type of drive, e.g. a servomotor or three-phase a.c. motor must be agreed with TAKTOMAT
- On attaching the drive, note and follow the manufacturer's operating instructions
- The oil level check and drain plugs and the vent valves must be freely accessible
- Note the spatial positions of the drive
- Fix the drive in the specified mounting points
- Tighten the screws to the specified torque

#### Recommended tools

The tools are not included in the standard scope of supply. They must be ordered from TAKTOMAT separately.

Type	Clearance hole	Designation	Quantity	Size	Item no.
Drive flange	Ø 9 mm	Assembly screw TMF1000	2	M8	ART00332104
Drive flange	Ø 13.5 mm	TMF2000 assembly screw	2	M12	ART00332101
Drive flange	Ø 13.5 mm	TMF3000 assembly screw	2	M12	ART00332101



## 5.1 Attaching the VTMF1010

### 5.1.1 Attaching the flange plate

#### Fitting the flange plate to the rotary drum

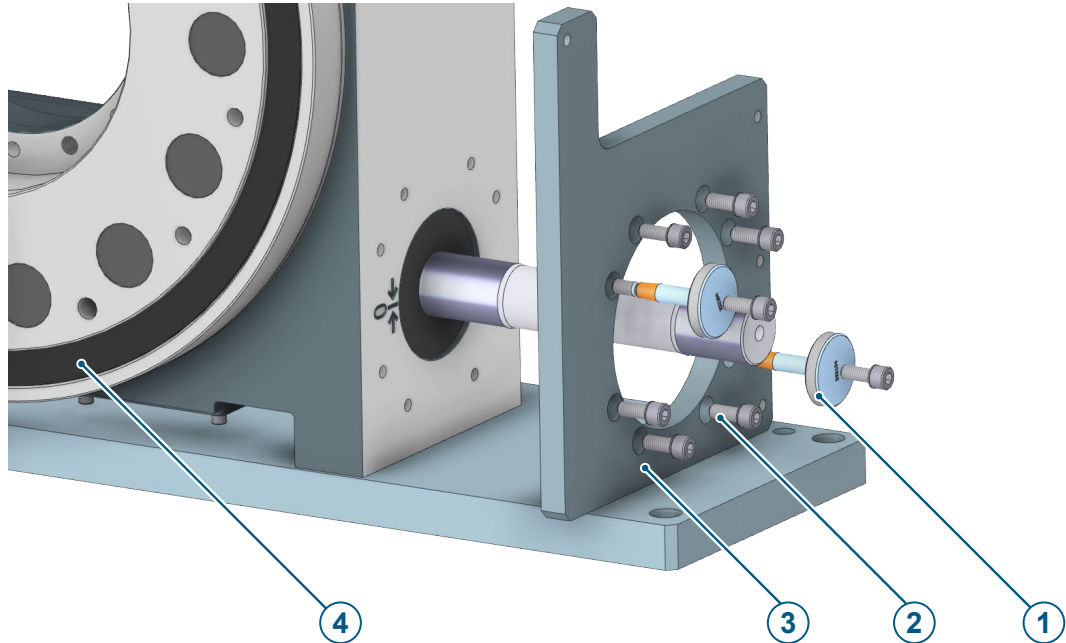

Fig. 6: Fitting the flange plate to the rotary drum

1	Assembly screw (2x) (purchased part: optional)	2	Cylinder head screw DIN 912 (M8 x 30) with lock washer type S (8x)
3	Flange plate	4	Rotary drum

Fit the flange plate to the complete drive as follows:

1. Use the assembly screws (1) to align and secure the flange plate (3) on the rotary drum (4) (position diagonally). The centring device for the flange is secured on the assembly screws using the screwed-on tapered surface (indicated in colour).
  2. Fix the flange plate (3) with six hexagon socket head cap screws (2). Tighten the screws to the specified torque.
  3. Undo and remove the assembly screws (1).
  4. Screw in the remaining two hexagon socket head cap screws (2). Tighten the screws to the specified torque.
- ➔ The complete drive can be fitted to the rotary drum.

### Fitting the flange plate to the complete drive

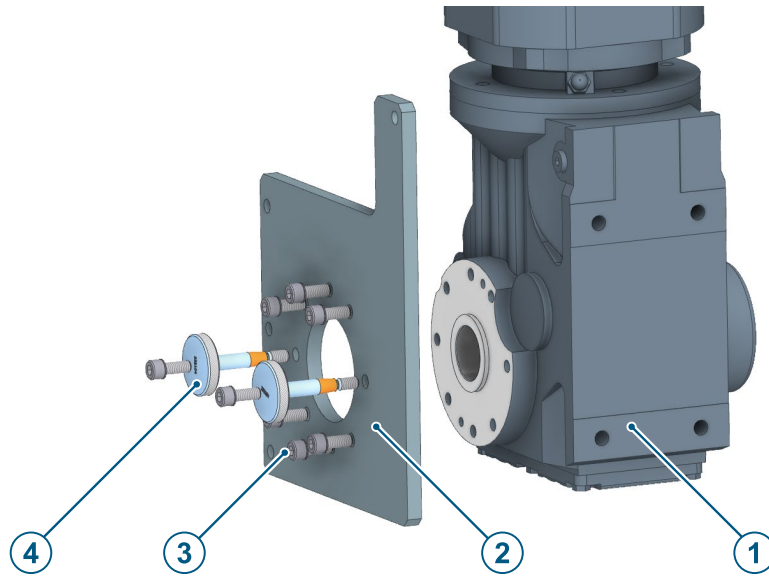

Fig. 7: Fitting the flange plate to the complete drive

1	Complete drive	2	Flange plate
3	Cylinder head screw DIN 912 (M8 x 30) with lock washer type S (8x), strength class 8.8	4	Assembly screw (2x) (purchased part: optional)

Fit the flange plate to the complete drive as follows:

1. Use the assembly screws (4) to align and secure the flange plate (2) on the complete drive (1) (position diagonally). The centring device for the flange is secured on the assembly screws using the screwed-on tapered surface (indicated in colour).
  2. Fasten the flange plate (2) to the complete drive with six cylinder head screws (3) using the free drilled holes. Tighten the screws to the specified torque.
  3. Undo and remove the assembly screws (4).
  4. Screw the remaining two cylinder head screws (3) into the vacated drilled holes in the flange plate. Tighten the screws to the specified torque.
- ➡ The complete drive can be fitted to the rotary drum.

### Fitting the complete drive to the rotary drum

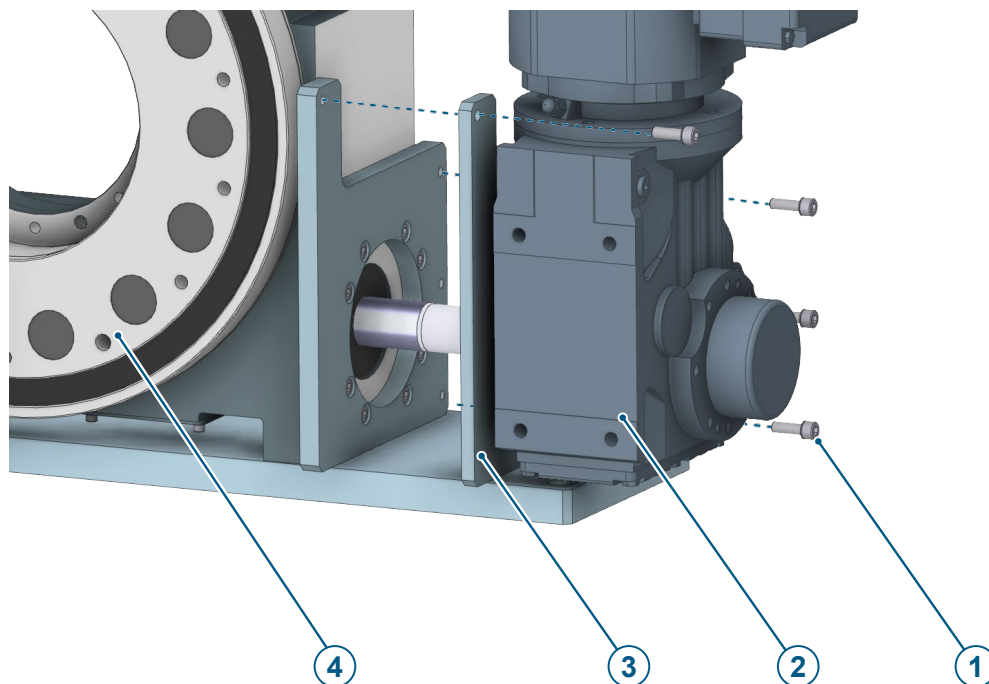

Fig. 8: Fitting the complete drive to the rotary drum

1	Cylinder head screw DIN 912 (M8 x 30) with lock washer type S (4x)	2	Complete drive
3	Flange plate	4	Rotary drum

Attach the complete drive to the rotary drum as follows:

- ✓ The flange plates have been fitted to the complete drive and the rotary drum.
  1. Push the complete drive (2) onto the drive shaft.
  2. Screw the flange plates with four hexagon socket head cap screws (1) and lock washers. Tighten the screws to the specified torque.

### 5.1.2 Attaching the mounting plate on the rotary drum

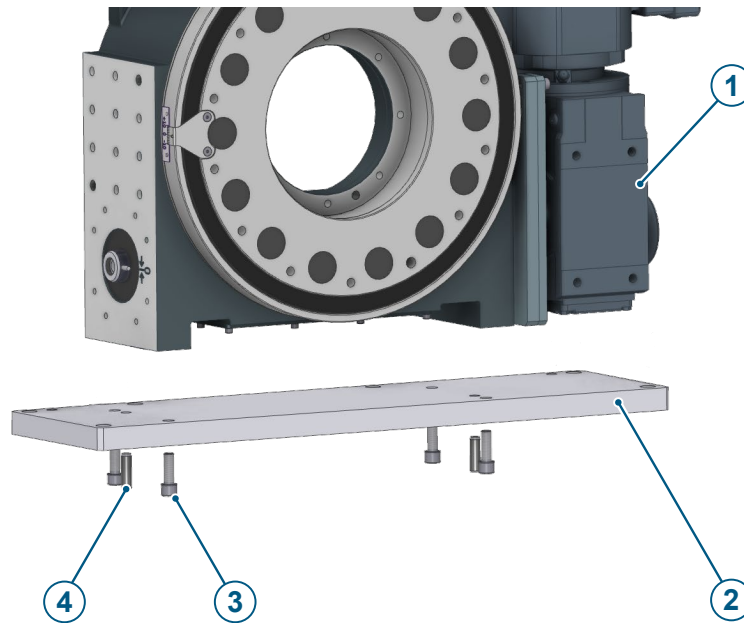

Fig. 9: Fitting the mounting plate to the rotary drum

1	Rotary drum with complete drive	2	Mounting plate
3	Screw DIN 912 M8 x 30 (4x)	4	Alignment pin ISO 8735 – 12 x 36 – A (2x)

Before the rotary drum can be fitted to the system, a mounting plate is attached to the rotary drum.

To do so, proceed as follows:

1. Insert the alignment pins (4) into the mounting plate from above.
  2. Position the rotary drum (1) on the alignment pins (4).
  3. Fasten the mounting plate (2) to the rotary drum (1) from below with the screws (3).
- ➔ The rotary drum can be fitted to the system.

### 5.1.3 Attaching the rotary drum to the machine or complete system

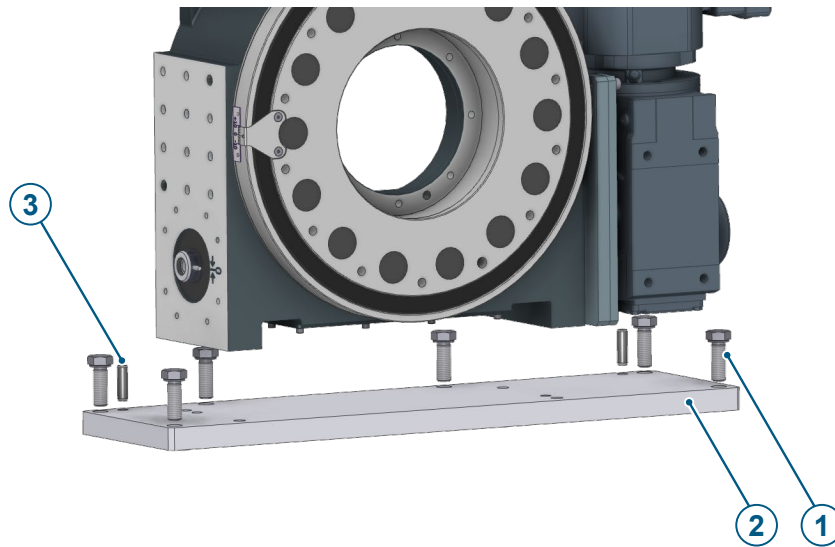

Fig. 10: Fitting the rotary drum to the machine or complete system

1	Screw DIN 961 M8 × 30 (6×)	2	Mounting plate
3	Alignment pin ISO 8735 – 12 – A (2×)		

Fit the rotary drum to the machine or complete system as follows:

1. Place the mounting plate (2) with the alignment pins (3) on the machine or complete system in the stipulated position.
2. Screw in the screws (1) and tighten them to the specified torque.

## 5.2 VTMF2010 attachment

### 5.2.1 Attaching the flange plate

#### Fitting the flange plate to the rotary drum

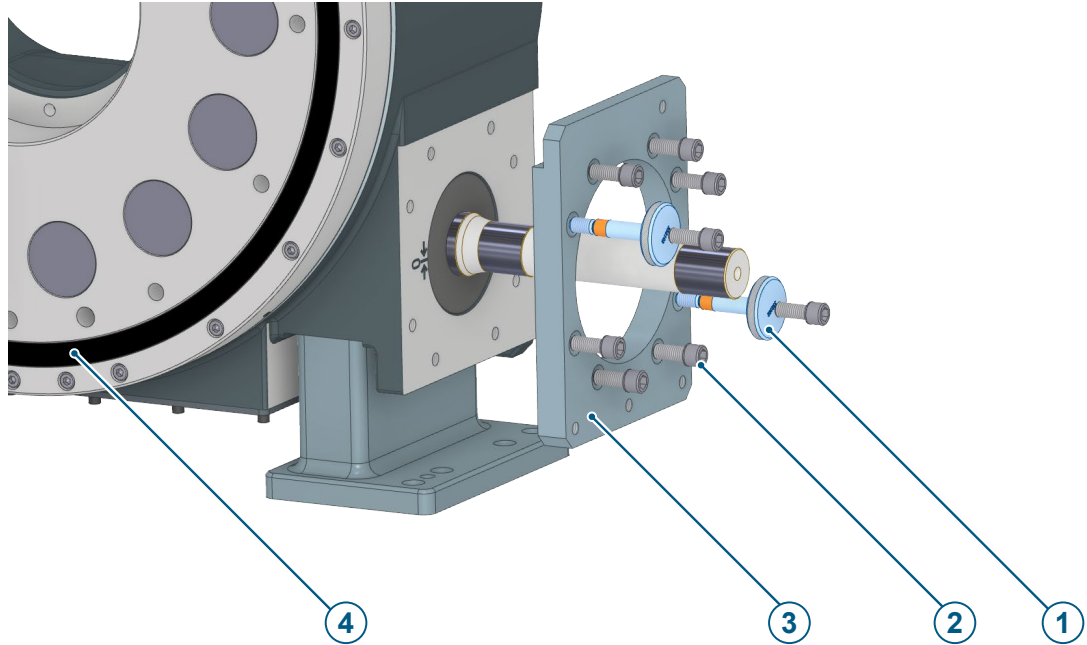

Fig. 11: Fitting the flange plate to the rotary drum

1	Assembly screw (2x) (purchased part: optional)	2	Cylinder head screw DIN 912 (M12 x 30) (8x) with lock washer type S (8x)
3	Flange plate	4	Rotary drum

Fit the flange plate to the complete drive as follows:

1. Use the assembly screws (1) to align and secure the flange plate (3) on the rotary drum (4) (position diagonally). The centring device for the flange is secured on the assembly screws using the screwed-on tapered surface (indicated in colour).
  2. Fix the flange plate (3) with six hexagon socket head cap screws (2). Tighten the screws to the specified torque.
  3. Undo and remove the assembly screws (1).
  4. Screw in the remaining two hexagon socket head cap screws (2). Tighten the screws to the specified torque.
- ➔ The complete drive can be fitted to the rotary drum.

### Fitting the flange plate to the complete drive

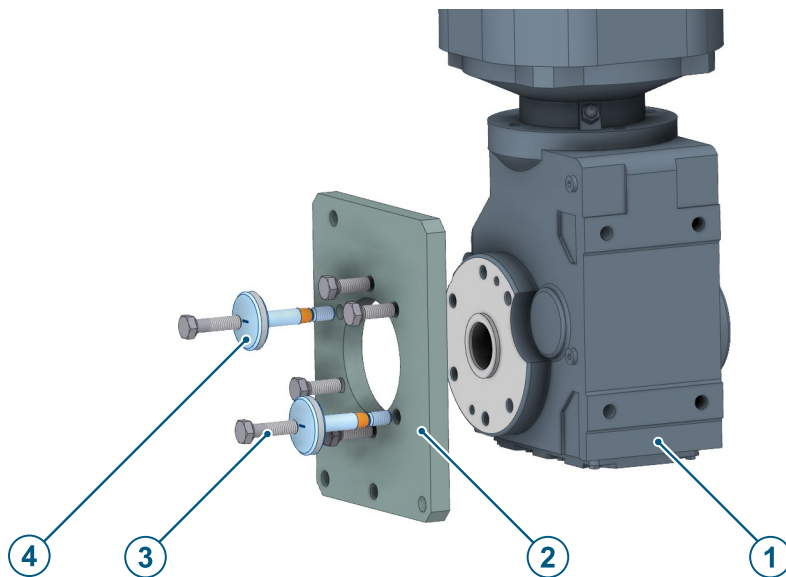

Fig. 12: Fitting the flange plate to the complete drive

1	Complete drive	2	Flange plate
3	Cylinder head screw DIN 933 (M12 x 35) (6x) with lock washer type S (6x)	4	Assembly screw (2x) (purchased part: optional)

Fit the flange plate to the complete drive as follows:

1. Use the assembly screws (4) to align and secure the flange plate (2) on the complete drive (1) (position diagonally). The centring device for the flange is secured on the assembly screws using the screwed-on tapered surface (indicated in colour).
  2. Fasten the flange plate (2) to the complete drive with four cylinder head screws (3) using the free drilled holes. Tighten the screws to the specified torque.
  3. Undo and remove the assembly screws (4).
  4. Screw the remaining two cylinder head screws (3) into the vacated drilled holes in the flange plate. Tighten the screws to the specified torque.
- ➔ The complete drive can be fitted to the rotary drum.

### Fitting the complete drive to the rotary drum

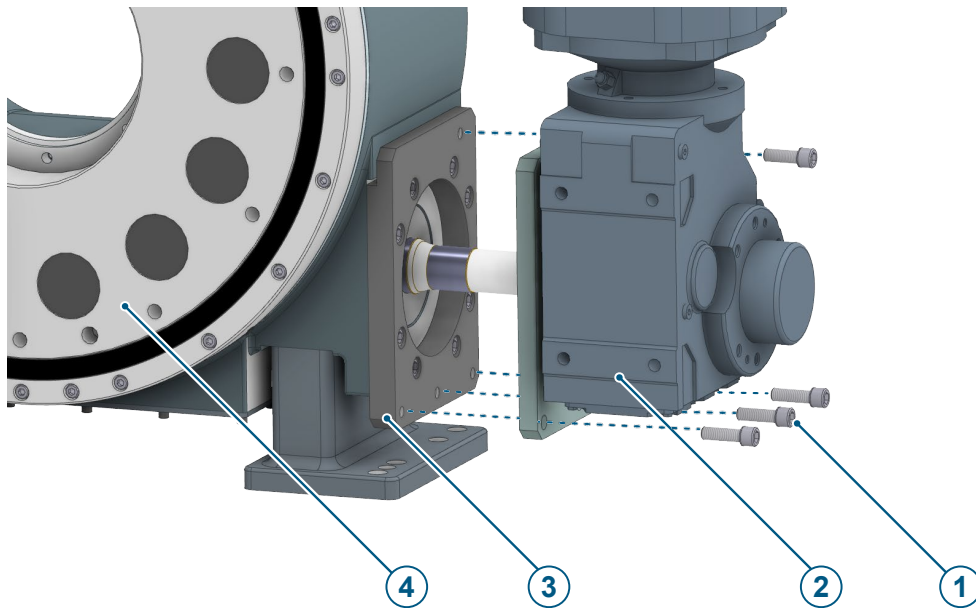

Fig. 13: Fitting the complete drive to the rotary drum

1	Cylinder head screw DIN 912 (M12 x 40) (4x) with lock washer type S (4x)	2	Complete drive
3	Flange plate	4	Rotary drum

Attach the complete drive to the rotary drum as follows:

- ✓ The flange plates have been fitted to the complete drive and the rotary drum.
  1. Push the complete drive (2) onto the drive shaft.
  2. Screw the flange plates with four hexagon socket head cap screws (1) and lock washers. Tighten the screws to the specified torque.



### 5.2.2 Attaching the housing base to the rotary drum

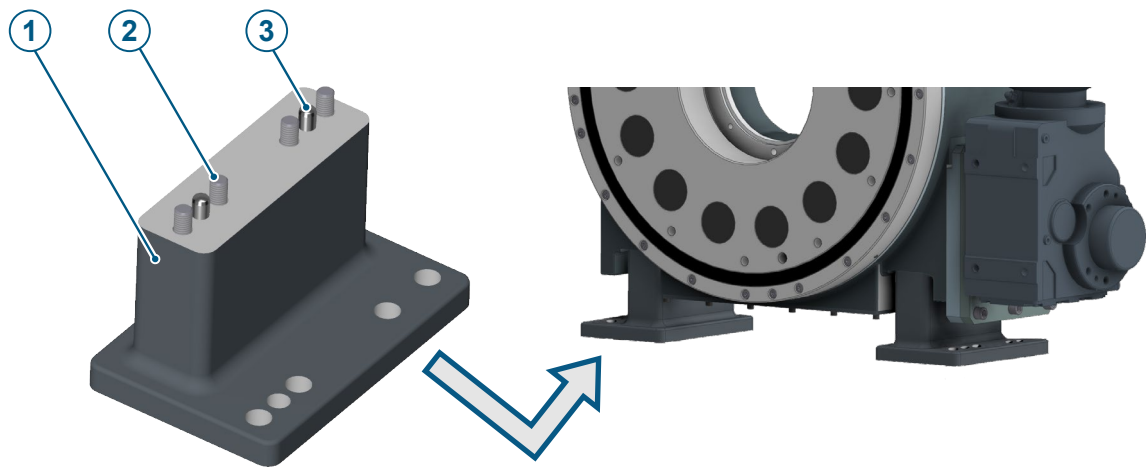

Fig. 14: Fitting the housing base to the rotary drum

1	Housing base (2x)	2	Screw DIN 912 (M12 x 130) (4 x for each housing base)
3	Alignment pin ISO 8735 (12 x 28 – A) (2x for each housing base)		

Before the rotary drum can be fitted to the system, housing bases are attached to the rotary drum.

To do so, proceed as follows:

1. Insert the alignment pins (3) into the housing base (1).
  2. Position the rotary drum on the housing base (1).
  3. Fasten the housing base (1) to the rotary drum with the screws (2).
- ➔ The rotary drum can be fitted to the system.

### 5.2.3 Attaching the rotary drum to the machine or complete system

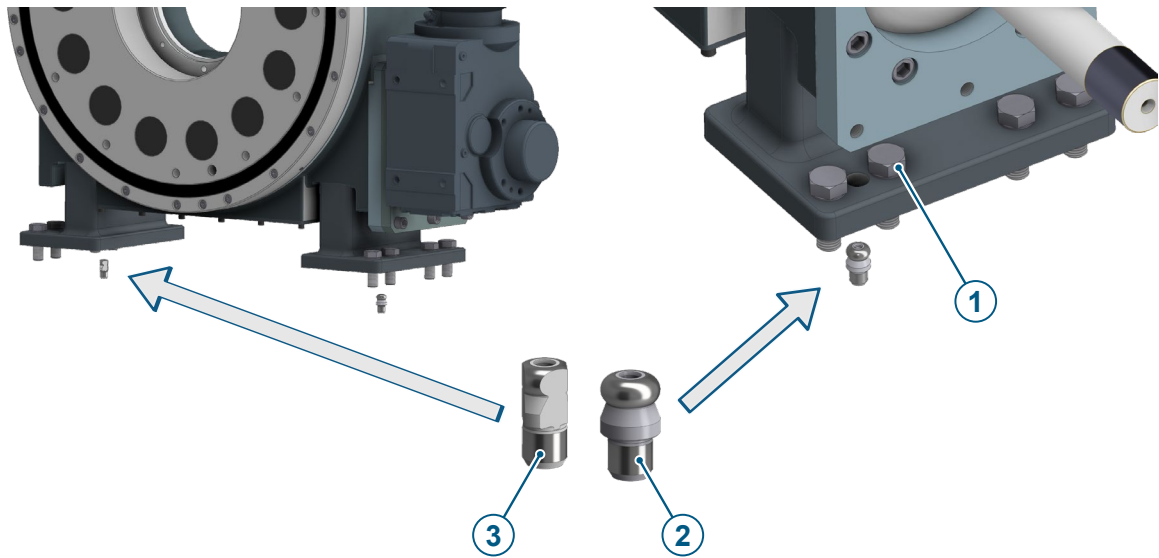

Fig. 15: Fitting the rotary drum to the machine or complete system

1	Screw DIN 961 M8 × 30 (8×)	2	Norelem location pin
3	Norelem mushroom head pin		

Fit the rotary drum to the machine or complete system as follows:

1. Fit the location pin (2) and the mushroom head pin (3) to the machine or complete system.
2. Place the rotary drum in the stipulated position.
3. Screw in the screws (1) and tighten them to the specified torque.

### 5.3 VTMF3010 attachment

#### 5.3.1 Attaching the flange plate

##### Fitting the flange plate to the complete drive

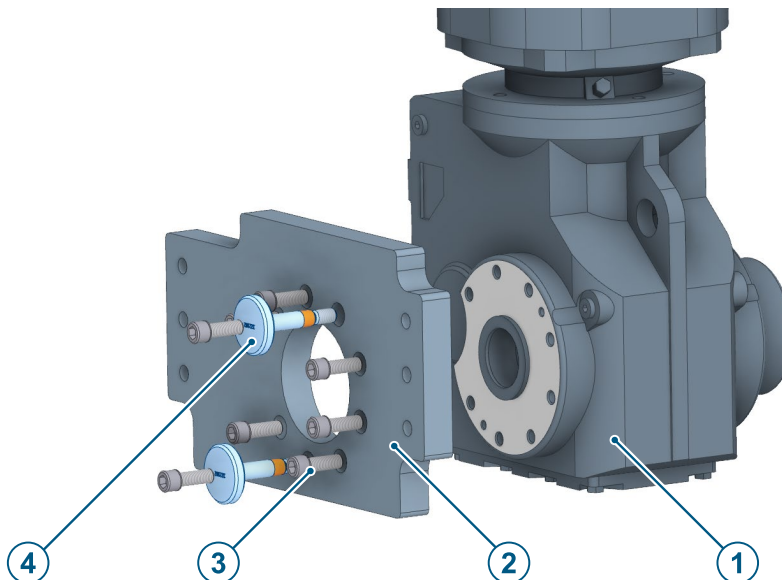

Fig. 16: Fitting the flange plate to the complete drive

1	Complete drive	2	Flange plate
3	Cylinder head screw DIN 912 (M12 x 30) with lock washer type S (8x)	4	Assembly screws (2x) (purchased part: optional)

Fit the flange plate to the complete drive as follows:

1. Use the assembly screws (4) to align and secure the flange plate (2) on the complete drive (1) (position diagonally). The centring device for the flange is secured on the assembly screws using the screwed-on tapered surface (indicated in colour).
  2. Fasten the flange plate (2) to the complete drive with six cylinder head screws (3) using the free drilled holes. Tighten the screws to the specified torque.
  3. Undo and remove the assembly screws (4).
  4. Screw the remaining two cylinder head screws (3) into the vacated drilled holes in the flange plate. Tighten the screws to the specified torque.
- ➡ The complete drive can be fitted to the rotary drum.

### Fitting the complete drive to the rotary drum

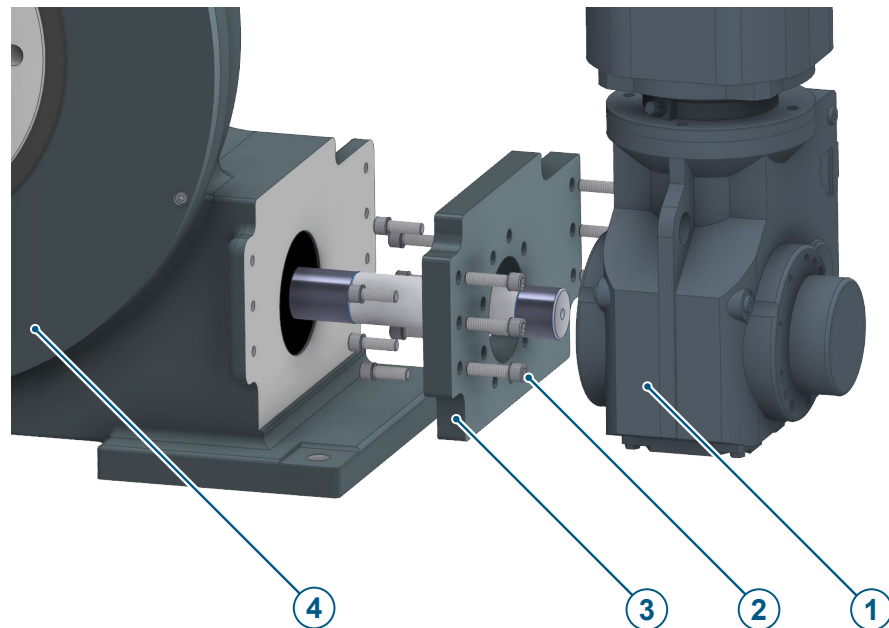

Fig. 17: Fitting the complete drive to the rotary drum

1	Complete drive	2	Cylinder head screw DIN 912 (M12 x 45) with lock washer type S (6x)
3	Flange plate	4	Rotary drum

Attach the complete drive to the rotary drum as follows:

- ✓ The flange plate has been fitted to the complete drive.
  1. Push the complete drive (1) onto the drive shaft.
  2. Screw the flange plates in place using six cylinder head screws (2) and lock washers. Tighten the screws to the specified torque.

## 6 Operation

### NOTICE



#### Improper activation can cause material damage

- Inching mode is not permitted without a suitable universal controller (TIC)
- Use a suitable universal controller (TIC)

### General requirements for operation

Operation of the rotary indexer is only permitted in a complete, CE-compliant machine or system.

The rotary indexer may not be operated with defective or disabled safety devices.

### 6.1 Operating modes

#### ⚠ WARNING



#### Moving components

Moving components can cause serious injuries

- During operation, do not reach into moving components or work on moving components
- Do not dismantle or bypass protective covers

### Normal operation

In normal operation, the roll star / output flange moves in one direction from one position to the next. The rotational direction of the roll star / output flange corresponds to the rotational direction of the drive. The rotational direction of a three-phase a.c. motor can be reversed by swapping two phases of the supply voltage.

### Reversing operation (reciprocating operation)

In this mode the roll star / output flange oscillates (shuttles) continuously, back and forth between two positions. The drive of the partly completed machinery is reversed in the respective dwell phase.

### Inching mode

In inching mode, the roll star / output flange moves in small increments between two latching positions.

The cylinder is unable to accelerate and decelerate the accumulated load gently. As a result, high accelerations occur, which impact the mechanics. Inching may only be carried out with a suitable universal controller. A suitable controller is, for example, the TIC controller (TAKTOMAT Indexing Controller).

### Emergency stop

The emergency stop stops the movement of the roll star / output flange immediately. The resultant load that is built up impacts the mechanics. The emergency stop should therefore only be used in emergency situations.

## 7 Maintenance

Required personal protective equipment



### **CAUTION**

#### **Harmful substances**

Lubricants can cause health damage

- When using lubricants, note the information in the safety data sheets

Adhere to the information from the operating instructions provided by the respective manufacturer before maintenance work is carried out.

### **Before maintenance**

- Remove any oil, fuel or maintenance product from the rotary drum, connections and screwed fittings. In the process, adhere to the following:
  - Do not use any aggressive cleaning agents.
  - Use lint-free cleaning cloths.
- After cleaning, check all supply lines for any leaks, loosened connections, and signs of abrasion or damage.

### **After maintenance**

- Check the screw connections.

## 7.1 Maintenance tasks

### 7.1.1 Maintenance plan

Interval	Activity	Personnel
Daily	<ul style="list-style-type: none"> <li>• General visual inspection and check for noises</li> </ul>	Operator
Monthly	<ul style="list-style-type: none"> <li>• Check the rotary drum for oil leakage</li> <li>• Checking the oil level</li> </ul>	Operator
Half-yearly	<ul style="list-style-type: none"> <li>• Check for damage (visual inspection)</li> <li>• Remove dust deposits (especially on the ventilation grille of the drive unit)</li> <li>• Check electric cables for damage</li> <li>• Check pneumatic hoses for damage</li> </ul>	Qualified personnel
Annually	<ul style="list-style-type: none"> <li>• Check the rotary drum for clearance</li> </ul>	Qualified personnel

### 7.1.2 Checking the oil level

#### NOTICE

##### Damage to components



Improper refilling of the lubricant can cause material damage.

- Before checking the oil level, the rotary indexer must stand still for at least 30 minutes
- Check the oil level only when the indexer is at a standstill
- Do not overfill oil. Fill the oil only up to the level of the oil sight glass.

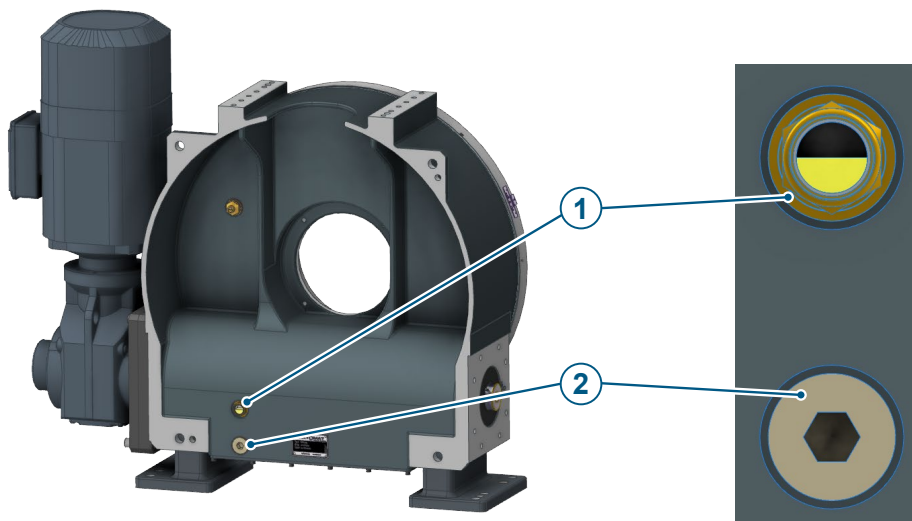

Fig. 18: Checking the oil level

1	Oil sight glass	2	Oil drain plug
---	-----------------	---	----------------

The rotary drum has an oil sight glass (1), and must be checked in accordance with the maintenance schedule to make sure that the oil level is correct. The correct oil level has been reached when the oil is in the middle of the oil sight glass (1). Top up as necessary.

### 7.1.3 Oil fill quantities

Gear type	Fill quantity [l] [dm <sup>3</sup> ]
VTMF1010-2010	5.5

## 7.2 Lubricating

### 7.2.1 Lubricant requirements

#### General

Careful lubrication is necessary to ensure operating reliability and a long life of the partly completed machinery. All lubricating points must be supplied with the specified oils and greases.

Clean soiled lubricating points carefully with petroleum or an appropriate means and then lubricate with new lubricant. After lubricating, the surplus lubricant must be removed and disposed of properly.

#### NOTICE



#### Component damage due to unsuitable lubricant

Mixing greases with different bases leads to gumming and decomposition of the greases and cancels the lubricating effect.

- Use lithium-saponified grease only for relubricating

#### Lubricating oils

Only use lubricating oils to DIN 51 517 (ISO VG 460).

#### Recommended gear oils

Manufacturer	Designation
Mobil	Mobilgear 600 XP 460
BP	Energol GR-XP 460
SHELL	Omala 460
LIQUI MOLY	meguin CLP 460 gear oil
Zeller+Gmelin	Divinol ICL ISO 460
Klüber	Klüberoil GEM 1 N

#### Lubricating greases

Only use lubricating greases to DIN 51 825-KP 2K.

#### Recommended grease

Manufacturer	Designation	Specification
Mobil	Mobilux EP2	KP2 K-30
BP	Energrease LS-EP 2	KP2 K-20
Aral	Aralub HLP 2	KP2 N-30
Fuchs-DEA	Renolit MP	KP2 K-40
Klüber	Centoplex 2	KP2 K-20
SHELL	Alvania G2	KP2 K-20



## 8 Troubleshooting

Fault	Possible cause	Remedy
Drive does not turn	<ul style="list-style-type: none"> <li>• No supply voltage</li> <li>• Drive contactor malfunction</li> <li>• Drive protection switch has triggered</li> <li>• Brake not released</li> </ul>	<ul style="list-style-type: none"> <li>• Check power supply</li> <li>• Change contactor</li> <li>• Let the drive cool down; latch the drive protection switch</li> <li>• Incorrectly connected or worn brake</li> </ul>
The motor turns but the indexer does not turn and the output flange has <u>no</u> clearance	<ul style="list-style-type: none"> <li>• External gear unit is defective</li> <li>• Safety clutch overload / disengaged</li> </ul>	<ul style="list-style-type: none"> <li>• Contact TAKTOMAT GmbH</li> <li>• Remove outer blockage</li> </ul>
The motor turns but the rotary indexer does not turn and the output flange has clearance	<ul style="list-style-type: none"> <li>• Cam follower ripped off by large overload</li> </ul>	<ul style="list-style-type: none"> <li>• Contact TAKTOMAT GmbH</li> </ul>
Drive turns with loud humming noises	<ul style="list-style-type: none"> <li>• Drive operates on 2 phases only</li> </ul>	<ul style="list-style-type: none"> <li>• Check fuses or drive contactor</li> <li>• Measure current in all 3 phases (voltage measurement is not enough)</li> </ul>
Lock bolt does not extend / retract	<ul style="list-style-type: none"> <li>• Lock bolt pin is blocked</li> <li>• No compressed air</li> <li>• Valve is blocked / defective</li> <li>• Actuator is defective</li> </ul>	<ul style="list-style-type: none"> <li>• Remove blockage</li> <li>• Check for correct setting of the restrictor check valve</li> <li>• Check hoses for damage</li> <li>• Check pressure gauge in maintenance unit for correct pressure (6 bar)</li> <li>• Test the valve</li> <li>• Replace the actuator</li> </ul>
Sensor transmits no signal	<ul style="list-style-type: none"> <li>• Sensor not operated</li> <li>• Cable defective</li> <li>• Sensor defective</li> <li>• No supply voltage</li> </ul>	<ul style="list-style-type: none"> <li>• Remove blockage</li> <li>• Check cable and replace if necessary</li> <li>• Replace sensor</li> <li>• Check power supply</li> </ul>

## 9 Disposal

Required personal protective equipment



### NOTE

#### Environmental damage

Improper disposal may result in environmental damage

- Dispose of components and operating materials in accordance with local regulations
- Observe the safety data sheets of the operating materials

### Materials used

The components are mainly made of the following materials:

- Copper (complete drive units, electrical cables)
- Steel and grey cast iron ( housings, attachments, shafts, bearings)
- Plastic (toothed belt, insulation, bearing)

### Preparation for disposal

1. Disconnect the system from all power supplies and secure it against being switched on again.
2. Wait 15 minutes until all live components are completely discharged.
3. Disassemble and dispose of assemblies and components in accordance with local environmental regulations.

## 10 Spare and wear parts



### NOTICE

**The use of unsuitable spare parts may result in material damage**

Spare parts must comply with the technical requirements specified by the manufacturer

- Only use original spare parts
  - Check spare parts for faults or defects prior to installation
- 

Spare and wear parts are always order-specific. A corresponding spare and wear parts list is available from TAKTOMAT on request. When ordering spare parts, always specify the serial number. The serial number is located on the nameplate.

## 11 Annexes

### 11.1 Content of the declaration of incorporation

(The original declaration of incorporation is included in the documentation)

<b>Translation of the original declaration of incorporation (in German) for partly completed machinery (Machinery Directive 2006/42/EC, Annex II 1 B)</b>		
<p><b>Manufacturer:</b>          TAKTOMAT GmbH          Rudolf-Diesel-Straße 14          D-86554 Pöttmes</p>		
<p><b>Description and identification of the partly completed machinery:</b></p>		
Your order No.:	-	
Our order No.:	-	
Product:	Rotary drum	
Type:	VTMF	
Serial number:	-	
Commercial name:	Rotary drum VTMF	
<p><b>The manufacturer declares that the following essential requirements of the Machinery Directive 2006/42/EC have been applied and met:</b></p>		
1.1.2, 1.1.3, 1.1.5, 1.3.2, 1.3.3, 1.3.4, 1.3.7, 1.5.3, 1.5.4, 1.6.1, 1.6.4, 1.7.1, 1.7.4		
<p>Reference of the applied harmonised standards according to Article 7 Section 2:          EN ISO 12100:2010 Safety of machinery — General principles for design — Risk assessment and risk reduction</p>		
<p>Furthermore, it is declared that the relevant technical documentation for this partly completed machinery has been compiled according to Annex VII Part B. The manufacturer undertakes to transmit in electronic form relevant information on the partly completed machinery within a reasonable time in response to a reasoned request by the national authorities.</p>		
<p><b>The partly completed machinery must not be put into service until the final machinery into which it is to be incorporated has been declared to be in conformity with the provisions of the Machinery Directive.</b></p>		
Responsible for the documentation:	TAKTOMAT GmbH	
Address:	Rudolf-Diesel-Straße 14, D-86554 Pöttmes	