

TAKTOMAT

passion for automation



Rotary Index Tables
Typ RT

Going full-pitch

– for a good turn



Passion for Automation

... this motto sums up our company philosophy and our overall approach toward business. Our broad product range forms the basis for our highly individual and customized solutions. That basis also includes the full range of drives available to the market: Barrel cams, Flat cams, Globoidal cams and servo technology.



The sky is the limit for the Taktomat product line. Flexible, made-to-order custom designs which are not featured in the product catalog have long been embedded in our corporate philosophy. We keep 10% of our entire workforce in reserve for these custom applications. Our skilled staff are available to assist our customers on a daily basis.

Our drives meet the highest standards regarding quality and precision. Our cams are manufactured in a different manner with regards to our competition, therefore it is often possible to use smaller rotary table sizes supplied by Taktomat instead of larger ones supplied by our competitors.

Our extensive design expertise enables us to meet customer requirements down to the last detail. We can combine the advantages of different forms of drives to create new value-added solutions which fit the bill completely. This is the added value which we have been offering to our customers in different sectors for many years.

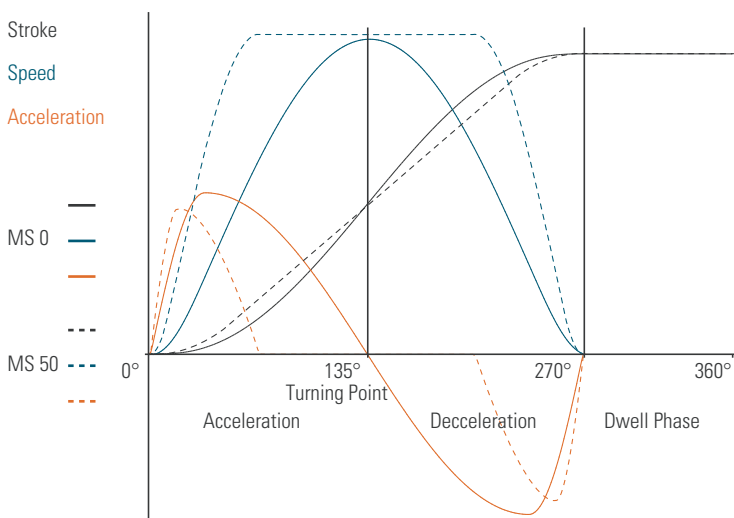

The rotary index table – design and mode of operation

The rotary table converts a uniform input motion into an intermittent output motion. The intermittent output motion is transmitted through our induction-hardened, precision-machined barrel cam. Mathematical laws of motion are applied to create a soft, smooth, zero-impact movement which is ideally tailored to the operation for any given case. Our design and construction results in a positive fit and zero-backlash positioning of the output flange (Tool mounting surface).

No further locking device is required on the output flange. Additional locking devices can lead to forced positioning which can ruin the index table over the long-term.

The force is transmitted through the index table input shaft either by a three-phase brake motor with worm gearing or by a chain wheel or belt pulley. This is mounted to the barrel cam without any further gear stages and in turn rotates the star wheel and cam followers together with the output flange.

The output flange rotates on wire-race bearings which are free of play and backlash (mounted in steel rings - not in cast). Custom-dimensioned shaft sealing rings form an internal and external seal on the index table.

Advantages for design engineers and special machine builders

- Housing machined on all sides. Suitable for use in any mounting position required.
- Mounting holes identical on top and bottom
- Large center through-hole which is large enough to feed entire shafts through, and not just small wiring looms.
- Dowel holes in housing and in output flange
- Recessed center column. No obstruction. Lengthened and machined to customer requirements
- Simultaneously rotating input shaft extension. Optional synchronization of other mechanical modules

Allowance for individual customer requirements

- Choice of drive
- Reinforced output flange bearing for higher tilting moment
- Optional friction clutch on drive
- Dwell and step angle can be tailored to requirements
- All sizes also available as NC index tables
- Custom specified color at no extra charge

Technical benefits for users

- High reliability and long service life
- Robust method of construction
- Induction-hardened cams: smaller sizes for higher load factors
- Needle or roller bearings fully immersed in oil bath. No wear
- Completely maintenance-free *
- Completely wear-free when used with optional universal control TIC (Taktomat Index Controller)

* The bearing ring on the RT400, RT500 and RT630 needs to be re-lubricated at maintenance intervals (see operating manual)

RT400 – The little one in the crowd

For mounted accessories up to Ø 3500mm. Applications in assembly facilities with large and heavy parts: welding, riveting, assembling, printing/labeling and lightweight machining operations. Suitable for pulley-drum motors. For use in assembly technology, the automotive industry and the ceramics industry.



RT400 Technical specifications

Main dimensions

Output flange Ø [mm]	460
Overall height (output flange screw-on surface) [mm]	316
Center opening Ø [mm]	110H8
Recommended max. size of rotating plate Ø [mm]	3500
Index table weight [kg]	325
Number of indexes	2,3,4,6,8,10,12,16,20,24,30,36
Other numbers on request	

Standard drives

Motor	Kobold/SEW
Gear unit	SAF77
Motor size	IEC80-132
Voltage [V]	230/400
Power [kW]	0,75-4,0

Precision

Index precision *	
In radian measure on cam follower Ø [mm]	±0,018
In angular seconds ["]	±20
Axial runout on cam follower Ø [mm]	0,01
Concentricity on cam follower Ø [mm]	0,01

Load on output flange

Axial force F_a [kN]	50
Radial force F_r [kN]	26
Tilting moment M_k [kNm]	10
Reinforced version	
Tilting moment M_k [kNm]	21

Load on central column

Axial force F_a [kN]	45
Tilting moment M_k [kNm]	5,5

Max. number of cycles [1/min]	145
Direction	clockwise, counterclockwise, reversing
Fitting position	horizontal, vertical, upside down

* The error in index precision is greater by a factor of 1.5 at 16 or more indexes due to multiple dwell on the drive cam.

Higher partial accuracies can also be achieved by agreement.

Load on output flange

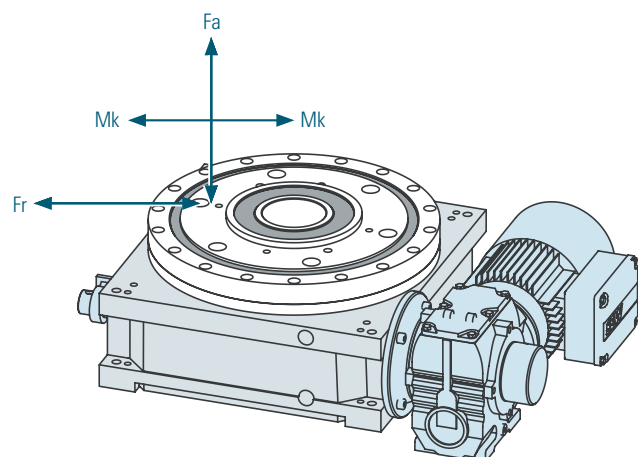

Load on central column

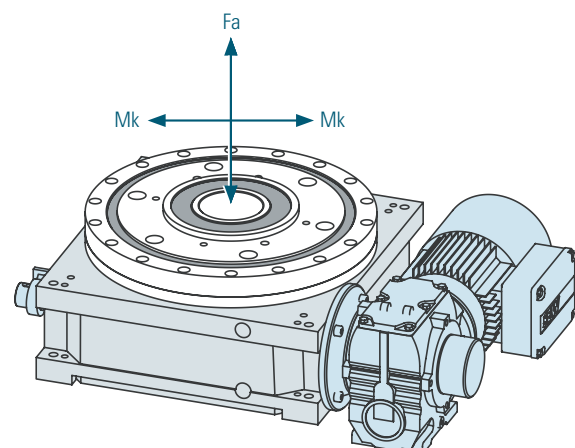

RT400 Load table

Speed		1	2	3	4	5	6	7	8	9	10	11
n												
2	t	0,57	0,78	1,06	1,56	1,88	2,13	2,37	2,84	3,22	4,08	5,64
	J	15,7	30	67	178	275	334	445	655	910	1480	2310
3	t	0,54	0,74	1	1,45	1,74	2	2,22	2,67	3,02	4	5,29
	J	29,9	60,5	123	315	430	590	810	1230	1650	2830	5890
4	t	0,48	0,67	0,9	1,31	1,58	1,8	2	2,4	3,02	3,82	4,73
	J	38,5	81	168	395	570	765	1060	1520	2350	3950	6480
5	t	0,48	0,67	0,9	1,31	1,58	1,8	2	2,4	3,02	3,82	
	J	50	104	204	503	772	1075	1210	2025	3300	5150	
6	t	0,48	0,64	0,9	1,31	1,58	1,8	2	2,4	3,02	3,82	
	J	62	133	271	652	987	1300	1740	2645	3700	7250	
8	t	0,48	0,64	0,9	1,29	1,58	1,8	2	2,49	3,02	3,82	
	J	92	197	398	952	1472	2015	2580	3490	5800	9150	
10	t	0,49	0,64	0,9	1,34	1,58		2	2,49	3,02		
	J	135	281	565	1365	1980		3200	4980	6850		
12	t	0,49	0,64	0,9	1,34	1,58		2	2,49	3,04		
	J	172	358	705	1730	2410		3810	5900	8700		
16	t		0,33	0,46	0,66	0,79	0,91	1	1,24	1,37		
	J		141	206	560	790	1005	1300	1730	2360		
20	t		0,32	0,46	0,66	0,79	0,9	1	1,24	1,37		
	J		178	335	670	990	1320	1590	2480	2970		
24	t		0,32	0,45	0,66	0,79	0,87	1	1,2	1,37		
	J		215	397	860	1180	1470	1910	2760	3550		
30	t		0,34	0,48	0,67		0,88	1	1,22	1,4		
	J		275	550	1080		1850	2420	3490	4580		
36	t			0,32	0,45		0,59	0,67	0,82	0,93	1,32	
	J			292	582		990	1290	1840	2410	4820	

n = Number of stops / 360° revolution of output flange
t = Step time in seconds

J = Mass moment of inertia (base plate + fixtures and parts) in Kg^m²

From n=16, the output flange steps 2 times per cam revolution.
From n=36, the output flange steps 3 times per cam revolution.

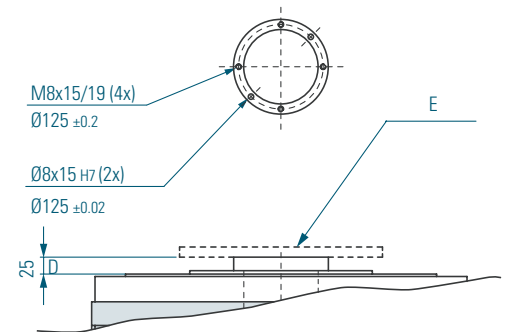
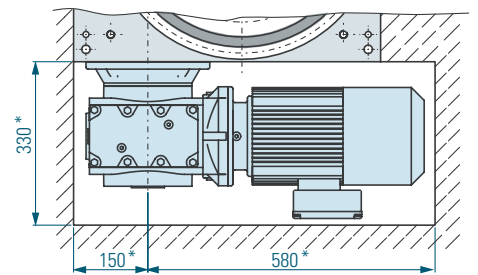
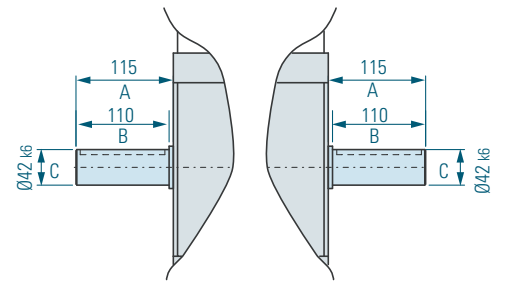
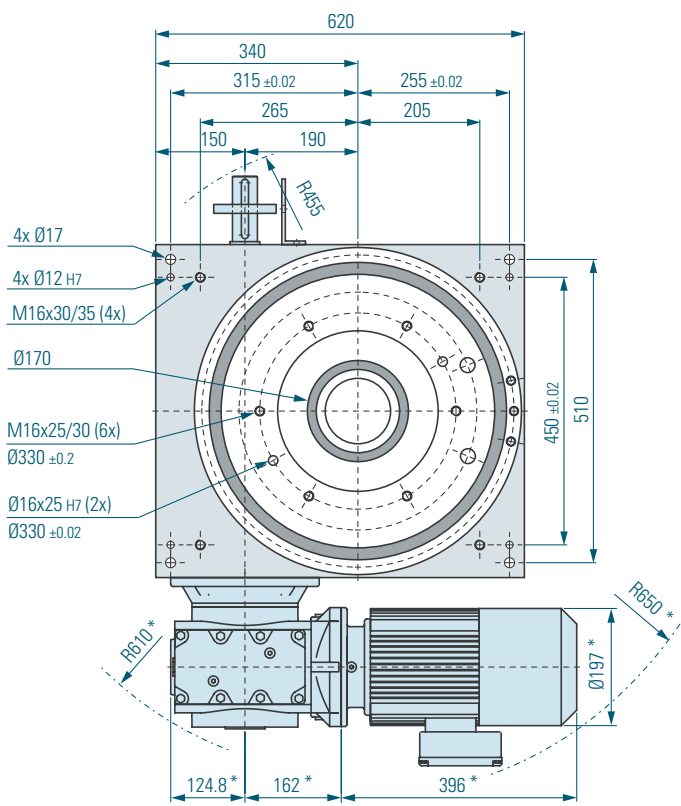
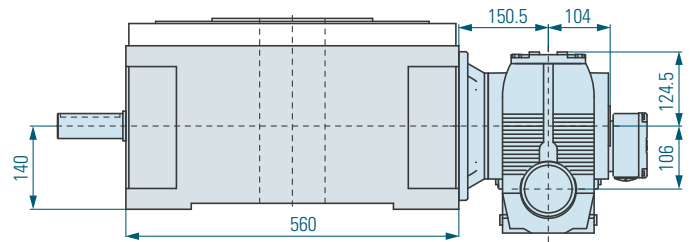
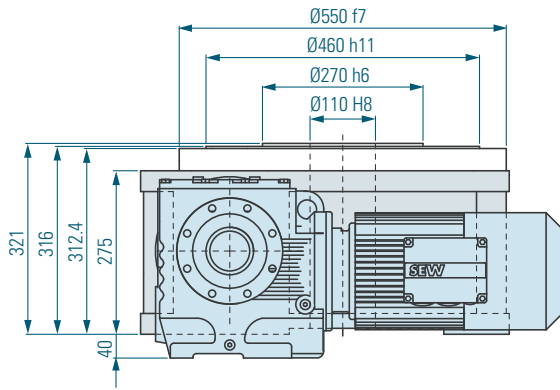

RT400 Dimensions

* Dimensions depend on the used drive

The dimensions shown here are the standard dimensions. The output flange, central column, housing and input shafts can be machined to your specifications.

The central column can also be designed as a flange.

Should you wish to drill additional holes, please consult us with regard to acceptable drilling depth.

⚠ Caution! Do not drill right through.

⚠ Please note that the opening for mounting the drive varies depending on the size of the drive.

A = Length of input shaft

B = Length of shaft to collar

C = Diameter of input shaft

D = Height of central column to supporting surface on output flange, standard is -0,5mm

E = Flange plate as an option

RT500 – The power-pack

For mounted accessories up to Ø 4500mm. Applications in assembly facilities with large and heavy parts: welding, riveting, assembling, printing/labeling and lightweight machining operations. For use in assembly technology and the automotive industry.

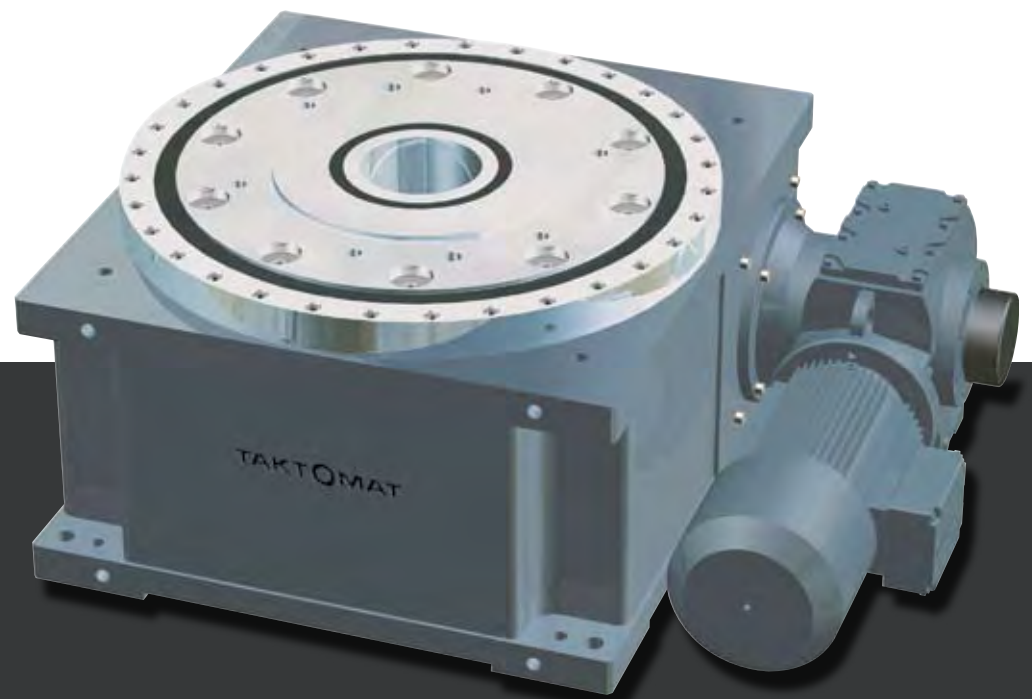

RT500 Technical specifications

Main dimensions

Output flange Ø [mm]	560
Overall height (output flange screw-on surface) [mm]	420
Center opening Ø [mm]	140 _{H8}
Recommended max. size of rotating plate Ø [mm]	4500
Index table weight [kg]	600
Number of indexes	2,3,4,6,8,10,12,16,20,24,30,36
Other numbers on request	

Standard drives

Motor	Kobold/SEW
Gear unit	SAF77-97
Motor size	IEC90-132
Voltage [V]	230/400
Power [kW]	1,5-5,5

Precision

Index precision *	
In radian measure on cam follower Ø [mm]	±0,018
In angular seconds ["]	±15
Axial runout on cam follower Ø [mm]	0,01
Concentricity on cam follower Ø [mm]	0,01

Load on output flange

Axial force Fa [kN]	84
Radial force Fr [kN]	49
Tilting moment Mk [kNm]	22
Reinforced version	
Tilting moment Mk [kNm]	40

Load on central column

Axial force Fa [kN]	60
Tilting moment Mk [kNm]	7,8

Max. number of cycles [1/min]	105
Direction	clockwise, counterclockwise, reversing
Fitting position	horizontal, vertical, upside down

* The error in index precision is greater by a factor of 1.5 at 16 or more indexes due to multiple dwell on the drive cam.

Higher partial accuracies can also be achieved by agreement.

Load on output flange

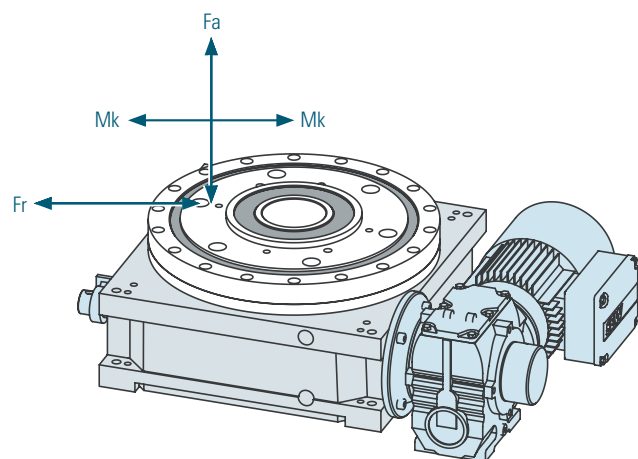

Load on central column

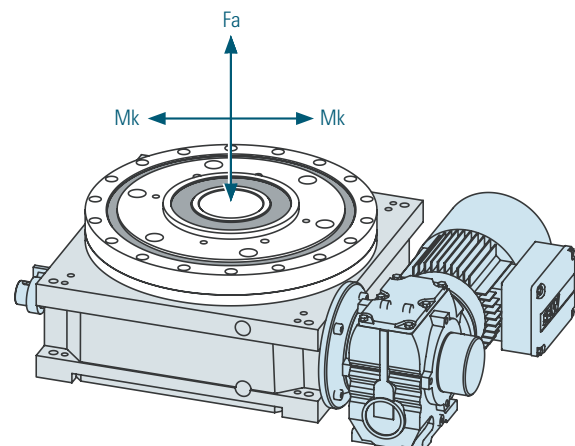

RT500 Load table

Speed		1	2	3	4	5	6	7	8	9	10	11	12	13
n														
2	t			1,07	1,52	1,87	2,13	2,37	2,90	3,33	4,27	5,73	6,84	9,70
	J			199,50	407,14	614,03	798,00	985,18	1479,57	1948,23	3191,99	5766,54	8197,70	16487,53
3	t			1,00	1,43	1,75	2,00	2,22	2,72	3,13	4,00	5,38	6,41	9,09
	J			378,28	772,00	1164,30	1513,12	1868,05	2805,49	3694,15	6052,49	10934,23	15544,07	31262,85
4	t			1,00	1,43	1,75	2,00	2,22	2,72	3,13	4,00	5,38	6,41	9,09
	J			586,43	1196,80	1804,96	2345,73	2895,96	4349,23	5726,87	9382,91	16950,86	24097,30	48465,44
5	t			1,00	1,43	1,75	2,00	2,22	2,72	3,13	4,00	5,38	6,41	9,09
	J			858,29	1751,61	2641,70	3433,16	4238,47	6365,44	8381,73	13732,63	24808,91	35268,29	70932,99
6	t			1,00	1,43	1,75	2,00	2,22	2,72	3,13	4,00	5,38	6,41	9,09
	J			1107,97	2261,17	3410,20	4431,89	5471,47	8217,20	10820,05	17727,56	32026,03	45528,13	91567,99
8	t			1,00	1,43	1,75	2,00	2,22	2,72	3,13	4,00	5,38	6,41	9,09
	J			1608,38	3282,41	4950,39	6433,53	7942,63	11928,44	15706,85	25734,11	46490,39	66090,63	132924,10
10	t			0,90	1,29	1,58	1,80	2,00	2,45	2,81	3,60	4,84	5,77	8,18
	J			1670,80	3409,80	5142,51	6683,21	8250,88	12391,38	16316,43	26732,84	48294,67	68655,59	138082,85
12	t			0,90	1,29	1,58	1,80	2,00	2,45	2,81	3,60	4,84	5,77	8,18
	J			2068,58	4221,58	6366,81	8274,31	10215,19	15341,44	20200,94	33097,23	59792,36	85000,68	170956,75
16	t		0,64	0,90	1,00	1,23	1,41	1,80	2,42	2,88	4,09			
	J		1293,71	1951,12	2535,67	3130,46	4701,41	6190,61	10142,70	18323,47	26048,60			
20	t	0,45	0,64	0,90	1,00	1,23	1,41	1,80	2,42	2,88	4,09			
	J	835,40	1704,90	3341,61	4125,44	6195,69	8158,22	13366,42	24147,34	34327,80	69041,43			
24	t	0,45	0,64	0,90	1,00	1,23	1,41	1,80	2,42	2,88	4,09			
	J	1034,29	2110,79	4137,15	5107,60	7670,72	10100,47	16548,61	29896,18	42500,34	85478,37			
30	t	0,45	0,64	0,90	1,00	1,23	1,41	1,80	2,42	2,88	4,09			
	J	1328,37	2710,95	5313,46	6559,83	9851,72	12972,32	21253,85	38396,50	54584,38	109782,27			
36	t	0,43	0,53	0,60	0,67	0,82	0,94	1,20	1,61	1,92	2,73			
	J	1407,19	2122,27	2758,10	3405,06	5113,81	6733,65	11032,41	19930,79	28333,56	56985,58			

n = Number of stops / 360° revolution of output flange
t = Step time in seconds

J = Mass moment of inertia (base plate + fixtures and parts) in Kg^m²

From n=16, the output flange steps 2 times per cam revolution.
From n=36, the output flange steps 3 times per cam revolution.

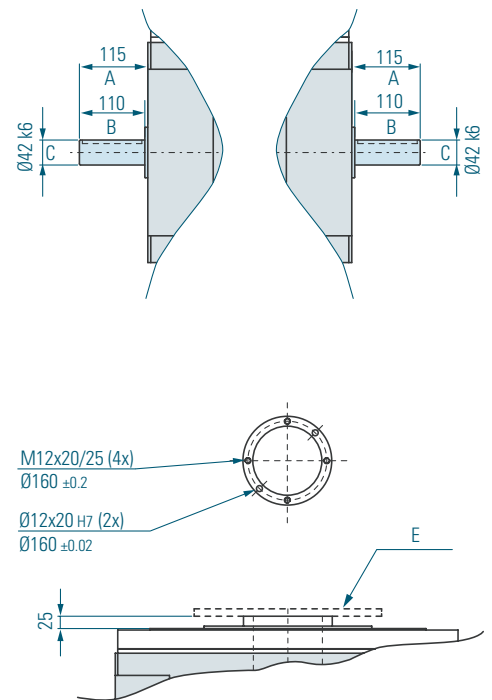
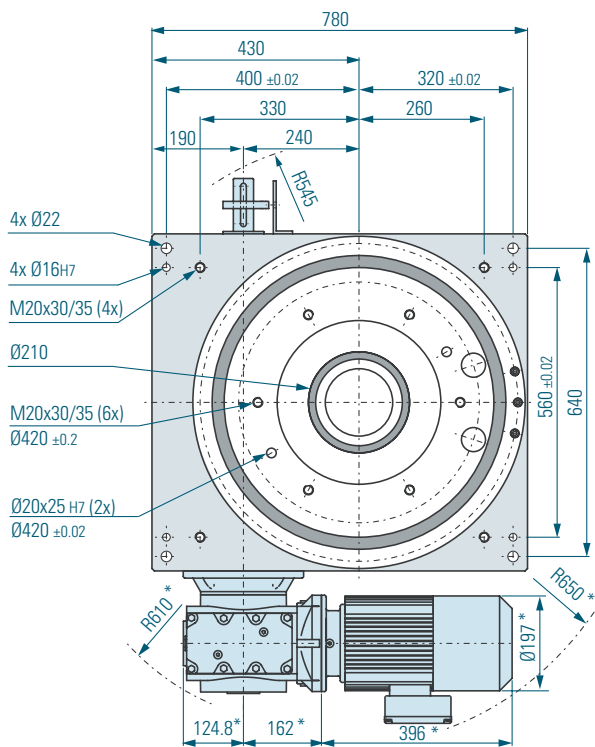
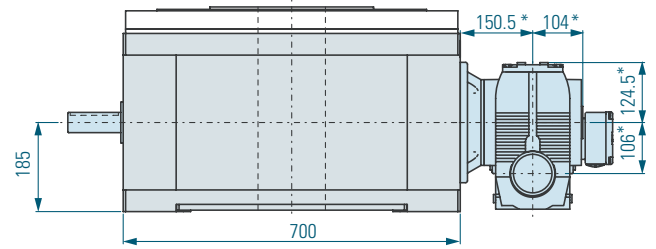
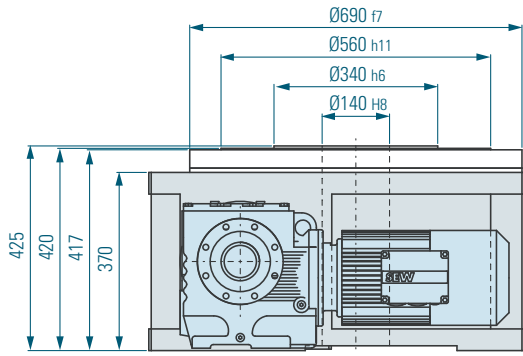

RT500 Dimensions

* Dimensions depend on the used drive

The dimensions shown here are the standard dimensions. The output flange, central column, housing and input shafts can be machined to your specifications.

The central column can also be designed as a flange.

Should you wish to drill additional holes, please consult us with regard to acceptable drilling depth.

⚠ Caution! Do not drill right through.

⚠ Please note that the opening for mounting the drive varies depending on the size of the drive.

A = Length of input shaft

B = Length of shaft to collar

C = Diameter of input shaft

D = Height of central column to supporting surface on output flange, standard is -0,5mm

E = Flange plate as an option

RT630 – The weightlifter

For mounted accessories up to Ø 6000mm. Applications in assembly facilities with large and heavy parts: welding, riveting, assembling, printing/labeling and lightweight machining operations. For use in assembly technology and bodywork in the automotive industry.

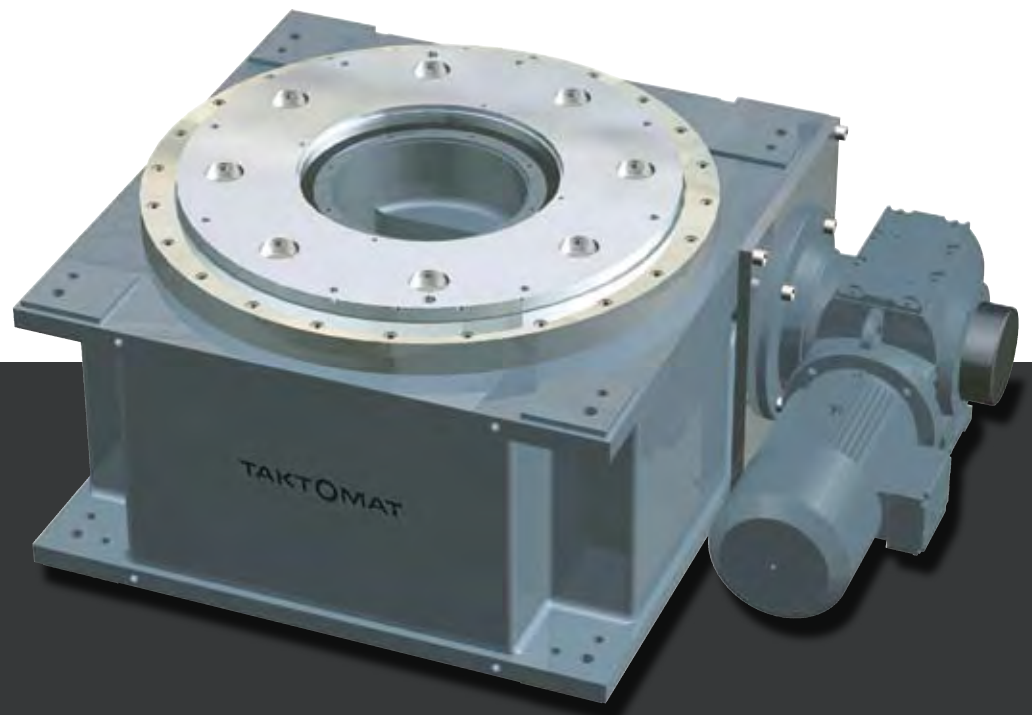

RT630 Technical specifications

Main dimensions

Output flange Ø [mm]	778
Overall height (output flange screw-on surface) [mm]	560
Center opening Ø [mm]	250H8
Recommended max. size of rotating plate Ø [mm]	6000
Index table weight [kg]	1600
Number of indexes	2,3,4,6,8,10,12,16,20,24,30,36
Other numbers on request	

Standard drives

Motor	Kobold/SEW
Gear unit	SAF87/97
Motor size	IEC100-132
Voltage [V]	230/400
Power [kW]	3-7,5

Precision

Index precision *	
In radian measure on cam follower Ø [mm]	±0,023
In angular seconds on cam follower Ø ["]	±15
Axial runout on cam follower Ø [mm]	0,01
Concentricity on cam follower Ø [mm]	0,01

Load on output flange

Axial force Fa [kN]	145
Radial force Fr [kN]	86
Tilting moment Mk [kNm]	41
Reinforced version	
Tilting moment Mk [kNm]	72

Load on central column

Axial force Fa [kN]	80
Tilting moment Mk [kNm]	9

Max. number of cycles [1/min] 105

Direction clockwise, counterclockwise, reversing

Fitting position horizontal, vertical, upside down

Load on output flange

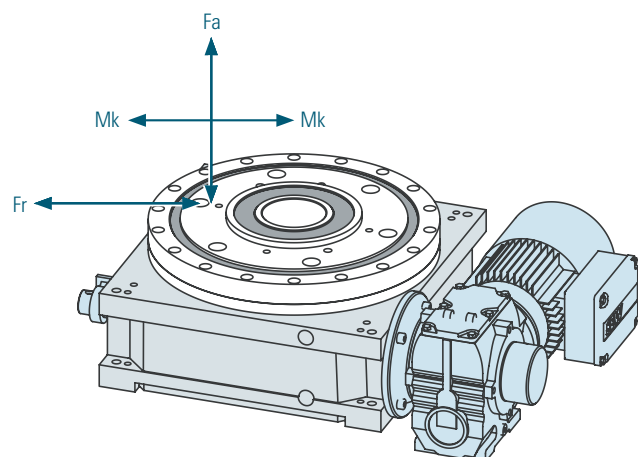

Load on central column

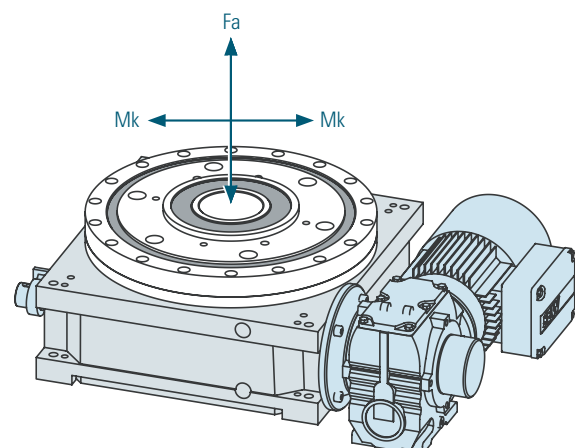

* The error in index precision is 5" - 8" greater at 16 or more indexes due to multiple dwell on the drive cam.

RT630 Load table

Speed		1	2	3	4	5	6	7	8	9	10	11	12	13
n														
2	t			1,07	1,52	1,87	2,13	2,37	2,90	3,33	4,27	5,73	6,84	9,70
	J			256	523	789	1026	1266	1900	2504	4102	7411	10535	21189
3	t			1,00	1,43	1,75	2,00	2,22	2,72	3,13	4,00	5,38	6,41	9,09
	J			485	989	1492	1939	2394	3595	4734	7756	14011	19918	40060
4	t			1,00	1,43	1,75	2,00	2,22	2,72	3,13	4,00	5,38	6,41	9,09
	J			793,91	1620,22	2443,55	3175,63	3920,53	5887,96	7753,01	12702,53	22947,98	32622,79	65612,25
5	t			1,00	1,43	1,75	2,00	2,22	2,72	3,13	4,00	5,38	6,41	9,09
	J			1162,81	2373,09	3578,99	4651,25	5742,29	8623,92	11355,60	18605,02	33611,21	47781,62	96100,30
6	t			1,00	1,43	1,75	2,00	2,22	2,72	3,13	4,00	5,38	6,41	9,09
	J			1514,00	3089,79	4659,89	6055,99	7476,54	11228,46	14785,14	24223,98	43762,25	62212,30	125123,85
8	t			1,00	1,43	1,75	2,00	2,22	2,72	3,13	4,00	5,38	6,41	9,09
	J			2496,54	5094,98	7684,02	9986,15	12328,58	18515,39	24380,25	39944,61	72162,62	102586,21	206325,45
10	t			0,90	1,29	1,58	1,80	2,00	2,45	2,81	3,60	4,84	5,77	8,18
	J			2551,05	5206,22	7851,79	10204,18	12597,76	18919,64	24912,56	40816,74	73738,18	104826,02	210830,25
12	t			0,90	1,29	1,58	1,80	2,00	2,45	2,81	3,60	4,84	5,77	8,18
	J			3094,40	6315,10	9524,15	12377,59	15280,97	22949,37	30218,72	49510,35	89443,78	127153,06	255735,29
16	t		0,64	0,90	1,00	1,23	1,41	1,80	2,42	2,88	4,09			
	J		2128,19	4171,25	5149,70	7733,95	10183,73	16685,02	30142,61	42850,66	86182,95			
20	t	0,45	0,64	0,90	1,00	1,23	1,41	1,80	2,42	2,88	4,09			
	J	1310,24	2673,97	5240,97	6470,34	9717,32	12795,34	20963,89	30142,61	42850,66	86182,95			
24	t	0,45	0,64	0,90	1,00	1,23	1,41	1,80	2,42	2,88	4,09			
	J	1576,73	3217,81	6306,92	7786,32	11693,69	15397,74	25227,66	45575,47	64789,98	130308,18			
30	t	0,45	0,64	0,90	1,00	1,23	1,41	1,80	2,42	2,88	4,09			
	J	1975,48	4031,60	7901,94	9755,48	14651,03	19291,84	31607,75	57101,52	81175,39	163263,17			
36	t	0,43	0,53	0,60	0,67	0,82	0,94	1,20	1,61	1,92	2,73			
	J	2155,62	3251,01	4225,01	5216,06	7833,62	10314,97	16900,05	30531,08	43402,91	87293,65			

n = Number of stops / 360° revolution of output flange
t = Step time in seconds

J = Mass moment of inertia (base plate + fixtures and parts) in Kg^m

From n=16, the output flange steps 2 times per cam revolution.
From n=36, the output flange steps 3 times per cam revolution.

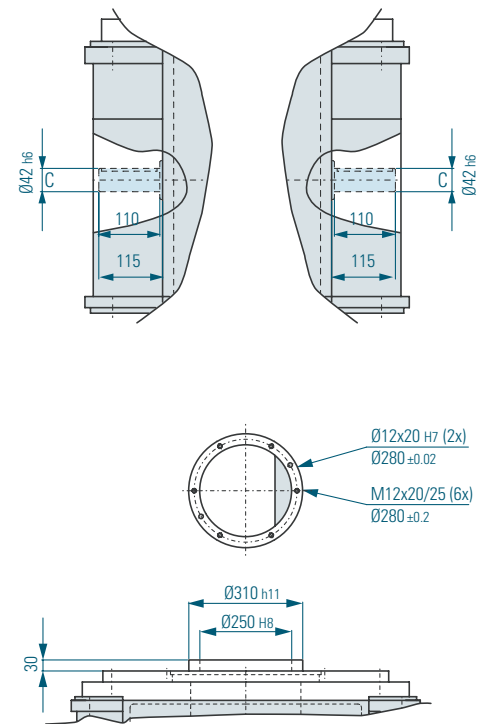
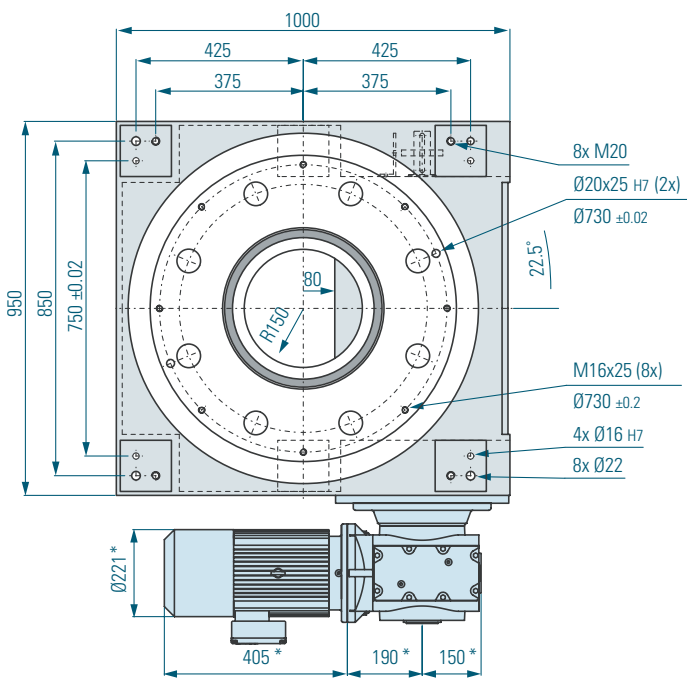
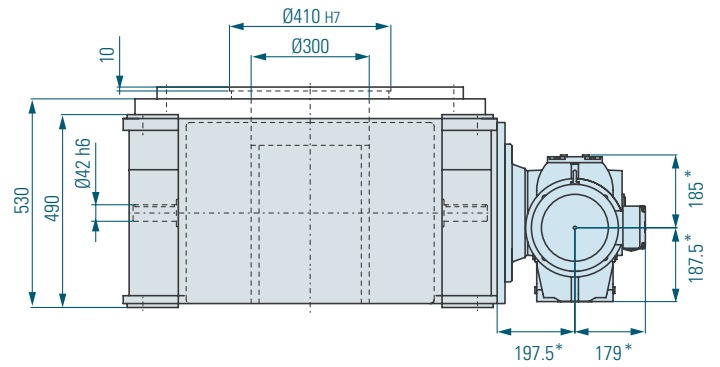
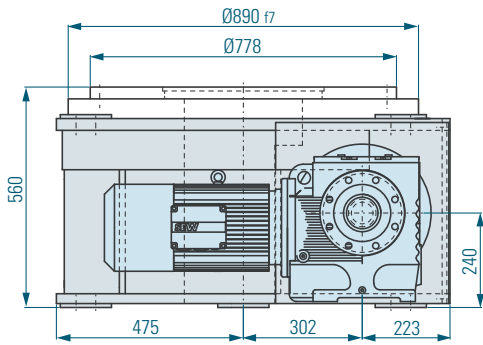

RT630 Dimensions

* Dimensions depend on the used drive

The dimensions shown here are the standard dimensions. The output flange, central column, housing and input shafts can be machined to your specifications.

The central column can also be designed as a flange.

Should you wish to drill additional holes, please consult us with regard to acceptable drilling depth.

⚠ Caution! Do not drill right through.

⚠ Please note that the opening for mounting the drive varies depending on the size of the drive.

A = Length of input shaft

B = Length of shaft to collar

C = Diameter of input shaft

D = Height of central column to supporting surface on output flange, standard is -0,5mm

E = Flange plate as an option

Universal Controller TIC

Your Advantages

An index table can be controlled in many different ways. We have developed this universal control to provide our customers with a user-friendly tool for operating the rotary table requiring minimal effort on the operator's part.

- Cycle time optimization is a result of stopping the drive exactly at the end of the dwell phase. The machine control receives the "enable" signal for the external processes as soon as the dwell phase begins. Elimination of time losses typically caused by mechanical contactors and variable PLC cycle times.
- Reduced installation and hardware costs.
- Motor contactor switches and mechanical or electronic contactors can be omitted. Only wiring protection is required.
- Single phase motor operation up to 2 kW possible.
- Fast, friction-free braking for emergency stop conditions.
- Gentle (soft) restart from intermediate positions or from an emergency stop.
- Soft and wear-free manual operation possible.
- Oscillating or change in direction of rotation possible without additional hardware.
- Speed can be easily changed.
- No frictional braking. The brakes only engage and lock after an emergency stop.
- When the TIC is used the rotary index table requires no maintenance.
- Short start-up times result, as the rotary index table software has already been initialized and integrated into the controller.
- Simple hand-shaking with the customer control unit (only start, stop & error signals).
- Simple interface between machine and rotary index table means quick error analysis via the telephone saving time and expensive servicing.



Schematic for single phase model

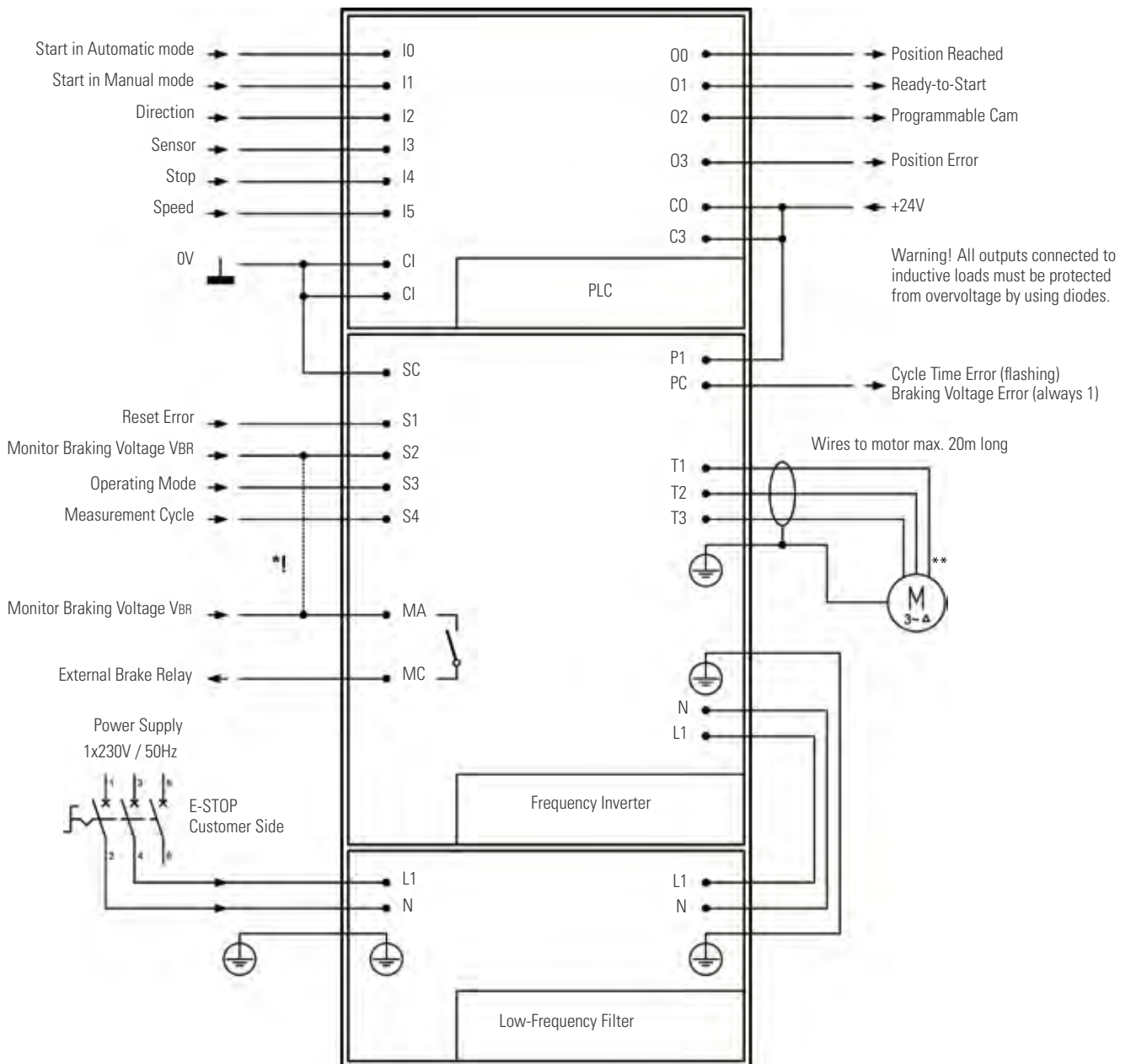

*!! Warning! If using brakes with a supply voltage of 230VAC or 400VAC, a jumper is NOT allowed between MC and S2. In this case S2 must be connected directly to +24V DC. Braking voltage monitoring is then no longer possible. Hence we strongly recommend a 24V DC brake when using this rotary index table.



** If a standard 230/400VAC three phase electric motor is interfaced to our single phase rotary index table controller TIC, a delta connection must be used. Please refer here to the description on the motor terminal block.

Inquiry and order form for rotary table type RT (1)

Firm _____ E-Mail Address _____
 Contact person _____ Project no. / Order no. _____
 Tel. / Fax _____ Date _____

Index plate Diameter [mm] _____
 Depth [mm] _____
 Material or weight _____

Fixtures and workpieces Quantity _____
 Mass/Station [kg] _____
 Reference diameter [mm] _____

- Stop mode (fixed step time, variable dwell time)
 Continuous mode (fixed step and dwell time)
 Required step time [s] _____
 Required dwell time [s] (continuous mode only) _____
 Number of cycles [1/min] _____
 Required service life (actual cycle time, normal 12,000 h)

 Additional forces and loads (please give details)

Please visit our website at www.takomat.de where you can download a program for calculating the rotary table data!

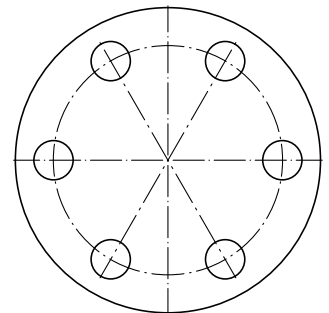
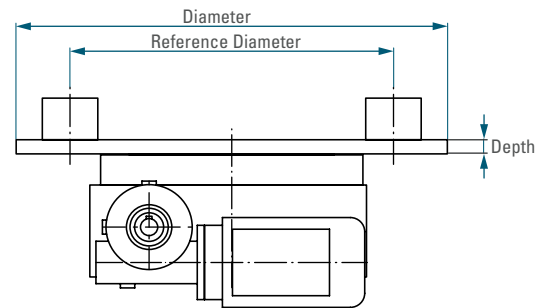

Possible mounting positions for the drive units

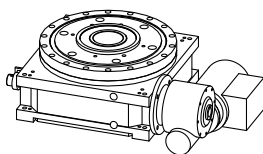

1SL90

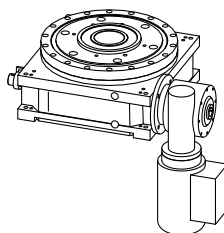

1SL180

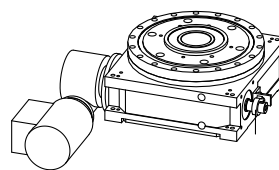

2SL90

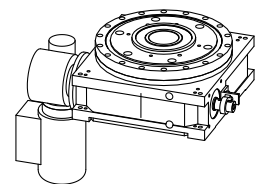

2SL180

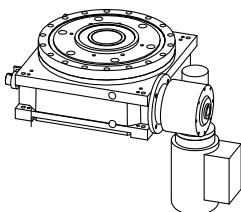

1SR180

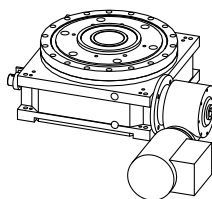

1SR270

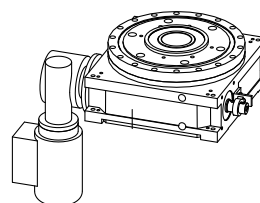

2SR180

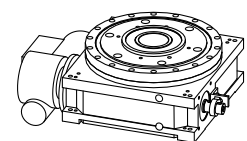

2SR270

Inquiry and order form for rotary table type RT (2)

Index Table

Type RT (100-630) _____

Number of stops _____

Index angle other than standard (see load table) _____

Mounting position (underneath) no. _____

Direction of rotation of output flange

Clockwise Counterclockwise Reverse

Cam lead Right (standard) Left

Standard central column Yes No

If No Extended by _____ mm

Standard hole pattern

Hole pattern as specified on drawing _____

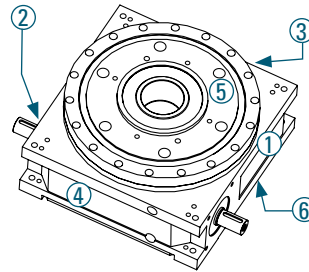

possible mounting positions

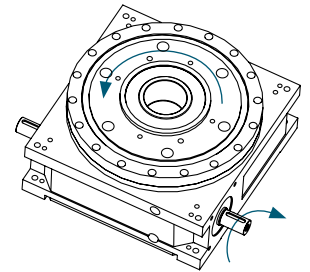

Cam Lead Right (Standard)

Drive

With drive

Drive position (see page 1) _____

Terminal box position (see below) _____

Motor voltage 230/400-50 Hz

Other voltage _____

Brake voltage 24V DC

Other voltage _____

Manual release on brake Yes No

Motor Handwheel Yes No

Input Safety Clutch Yes No

Additional specifications (temperature sensor, connector assembly, brand...)

Without drive

Direction of rotation of input shaft _____

Input shaft Ø _____ ; Length _____

Universal Controller TIC

Universal Controller TIC Yes No

Color

Cast housing RAL7016 other _____

Drive color of manufacturer other _____

Terminal box position

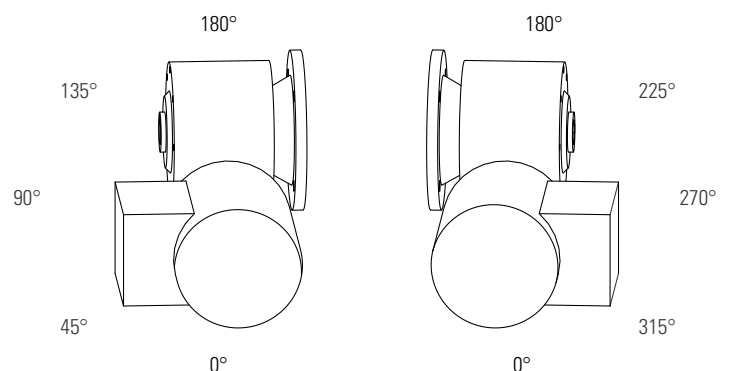

TAKTOMAT

passion for automation

Rudolf-Diesel-Str. 14 D 86554 Pöttmes Tel +49 (0)82 53-99 65-0 Fax +49 (0)82 53-99 65-50
info@taktomat.de www.taktomat.de

In Co-operation with

Motion
INDEX DRIVES, INC.