

TECNOTION®

direct drive in motion

IRONLESS LINEAR MOTOR SERIES

Superior precision







WE DIRECT DRIVE YOUR MOTION TECHNOLOGY

Direct drive motors from Tecnotion are seamlessly integrated into a wide range of applications, including semiconductors, machine tooling, robotics, display applications and printing. As an independent supplier of linear-, torque and vacuum motors, we offer specialized motor technology to place in your motion solutions.

We have distinguished ourselves for almost 30 years with the exclusive development and production of direct drive linear and torque motors. As a result, we succeed in providing the best motor solution for your motion needs, whether it is a catalogue or a custom motor. Thanks to our extensive experience we are used to designing and building any motion requirement with unmatched quality & performance.

Ironless motors

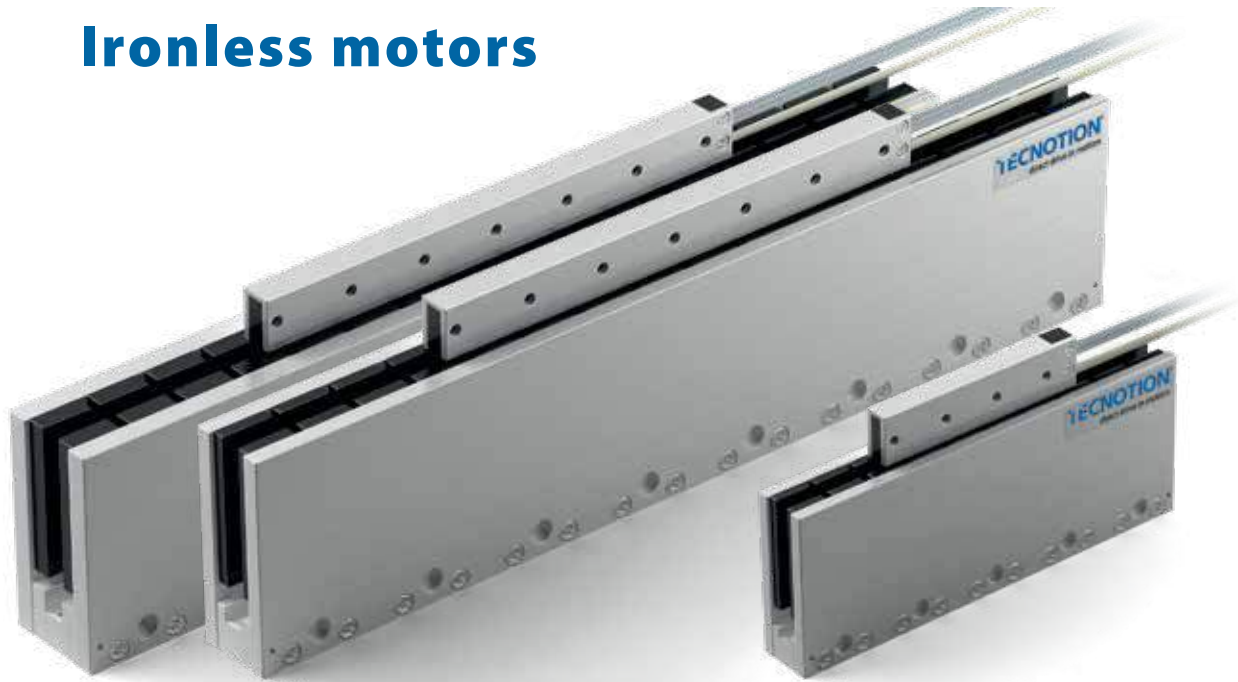

UXX / UXA series

F_p 615-4200 N F_c 120-846 N

The UXX is the most powerful standard ironless motor we have to offer. It is ideal for heavy duty industrial applications that demand ultra precision and maximum force output. The UXA is the economical alternative to the UXX. It's slightly less powerful, but makes up for this with a smaller footprint and an attractive price tag.

UL series

F_p 240-1200 N F_c 70-350 N

The high-end UL ironless motors are available in various configurations that can easily be adapted to application specific requirements. Because of their high speed, positioning accuracy, zero cogging and attraction force, many UL motors are successfully applied throughout the semiconductor industry.

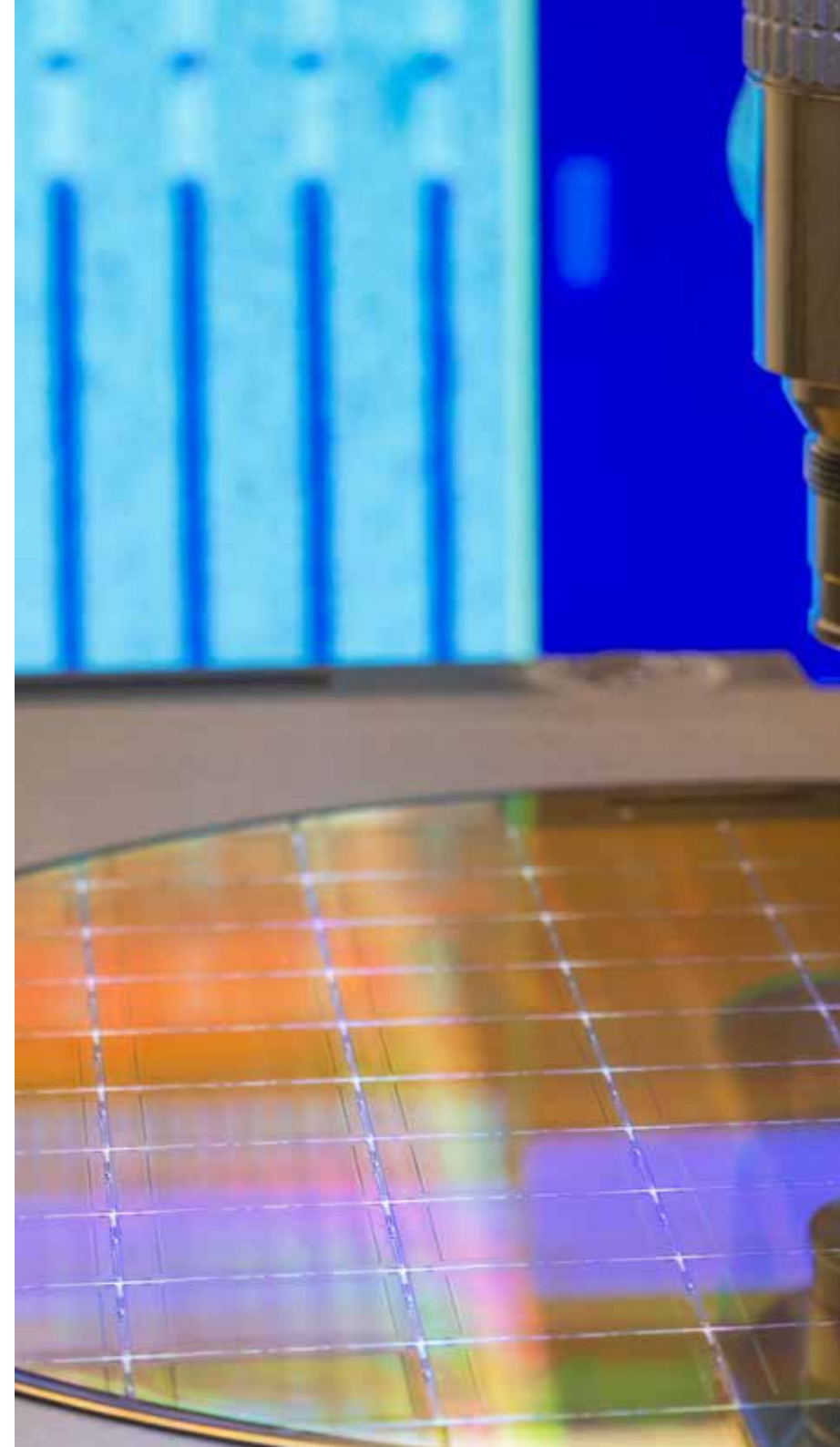

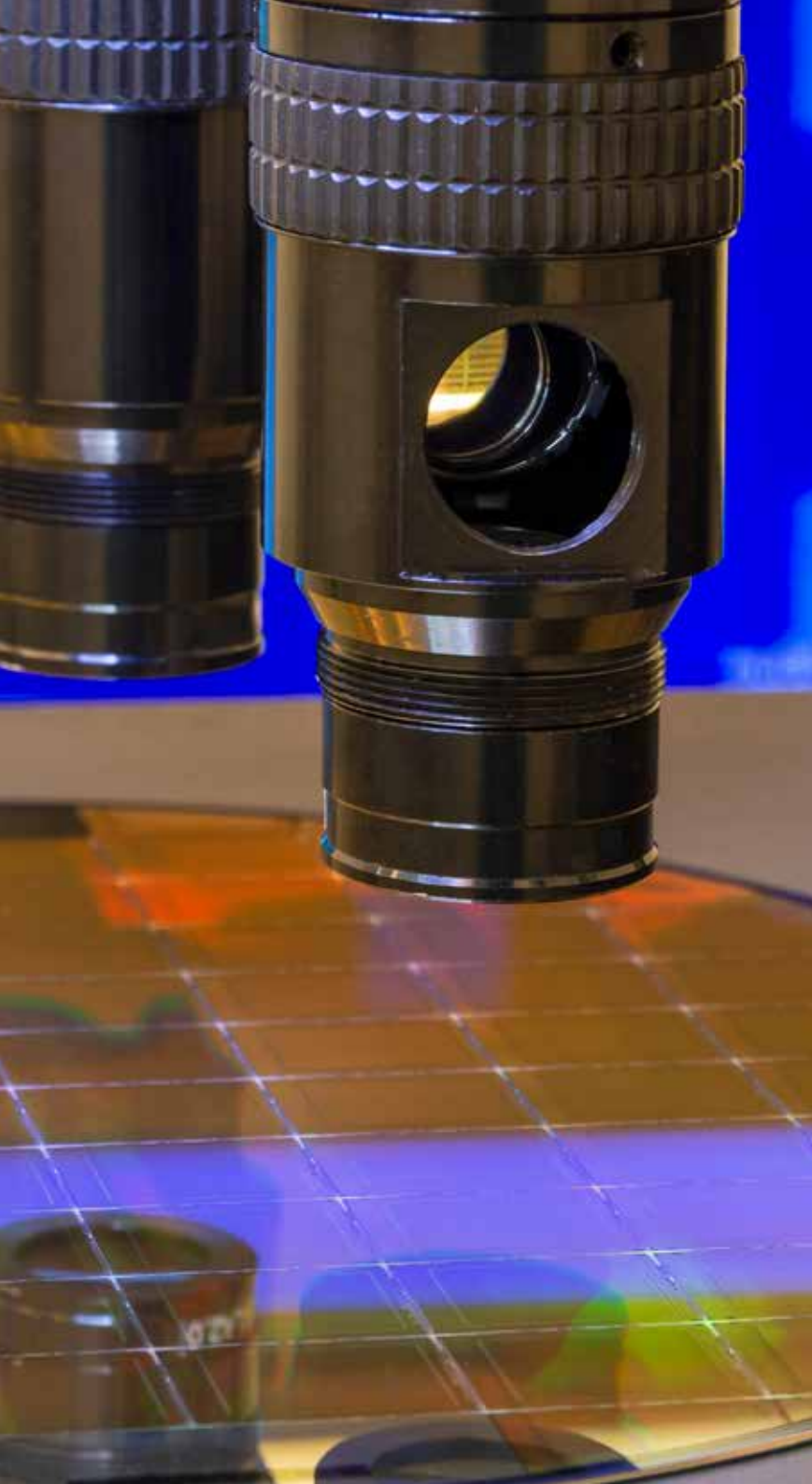

U	L	6	S
	M	12	N

U = Ironless

LM = Series type

6 12 = Number of coils

SN = Winding type



UM series

F_p 100-400 N F_c 29-116 N

The mid-range UM ironless motors stand out for their extremely high speed and exceptional thermal characteristics which are the result of our unique production techniques. This makes the compact UM motors especially suited for applications in which highly accurate measuring is required.



UF series

F_p 42.5-85 N F_c 19.5-39 N

The UF series is built specifically to sustain very high continuous forces for its footprint, which is only marginally larger than that of the UC. It is exceptionally suited for applications with high duty cycles, for instance in the medical and semiconductor markets or for pick & place systems.



UC series

F_p 36-72 N F_c 10-20 N

The UC is our smallest "off the shelf" motor. Weighing in at just a few grams, this versatile, compact and affordable motor is still able to sustain a continuous force of 10 or 20N. Due to its low weight it is also suited to operate in a vertical application environment.

Features

Ironless linear motor series

F/cm^3

High force density

More force in a small design means lowering footprint and it fits better in tight spaces.



High acceleration and dynamics

The outstanding force to mass ratio of the ironless coils enables unmatched system dynamics.



Low thermal resistance

Allowing good heat transfer, achieving an extremely high continuous force for all motors when using a decent size heatsink or active cooling.

Aluminum enclosed coil unit

Thermal management

Low thermal resistance (R_{th})

Aluminum strip

Coil

Magnet

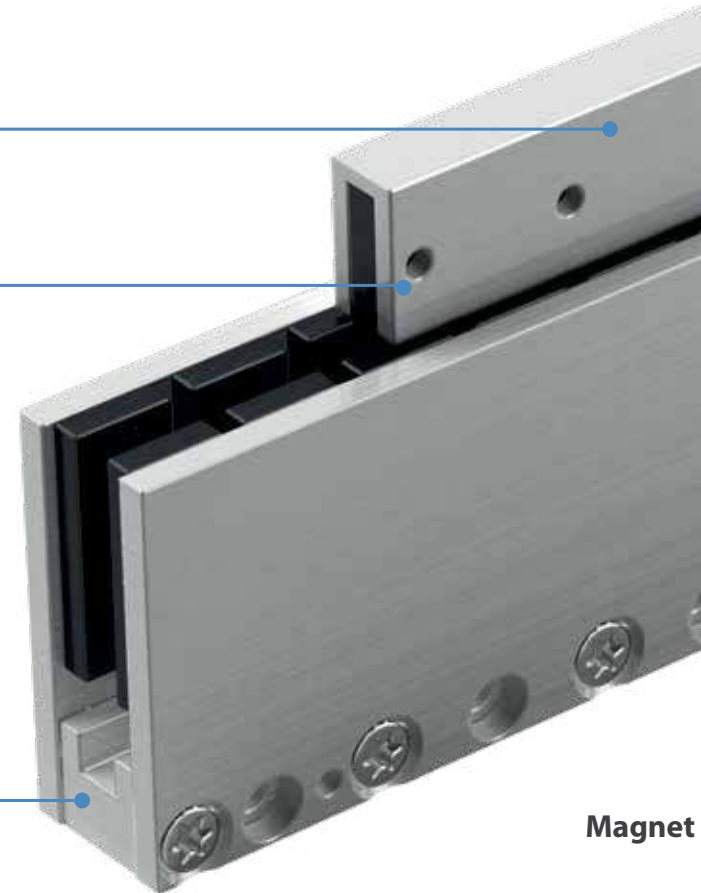

unit

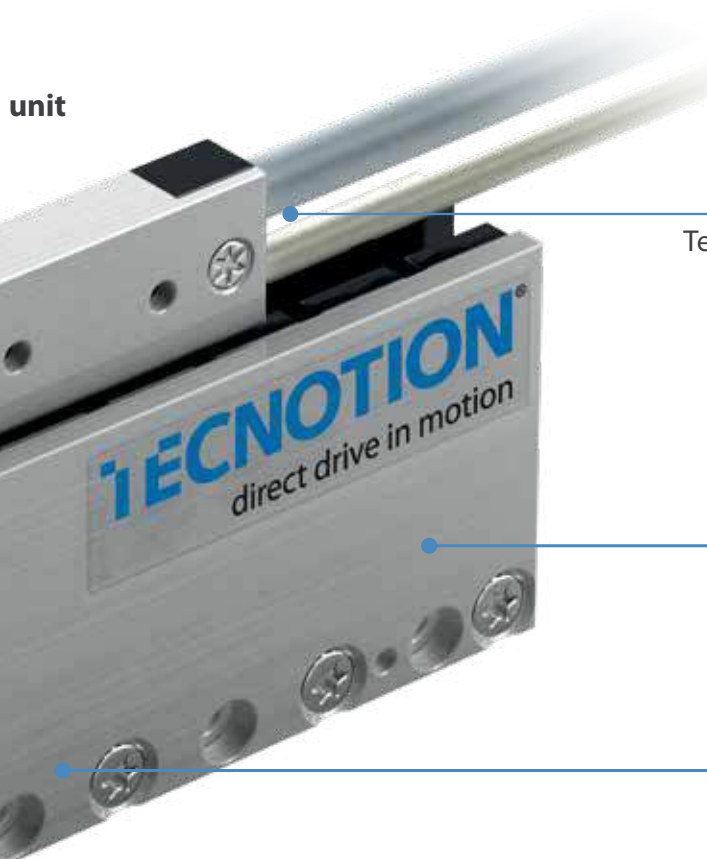

Power and sensor cable

Temperature measurement and cut-off sensor

Lifetime

Proven quality due to in-house testing

Manufacturing

Produced under high quality standards

yoke



Approved for CSA, CE, UKCA, REACH and RoHS

Ironless motors from Tecnotion are approved for CE, CSA, UKCA, REACH, and RoHS (UC and UF series are approved for CE, UKCA, REACH and RoHS).

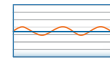

No cogging, extremely low force ripple

Ironless motors have no cogging effects, offering smooth motion and position accuracy in your application.

Accurate force constant and speed

Ironless motor force range

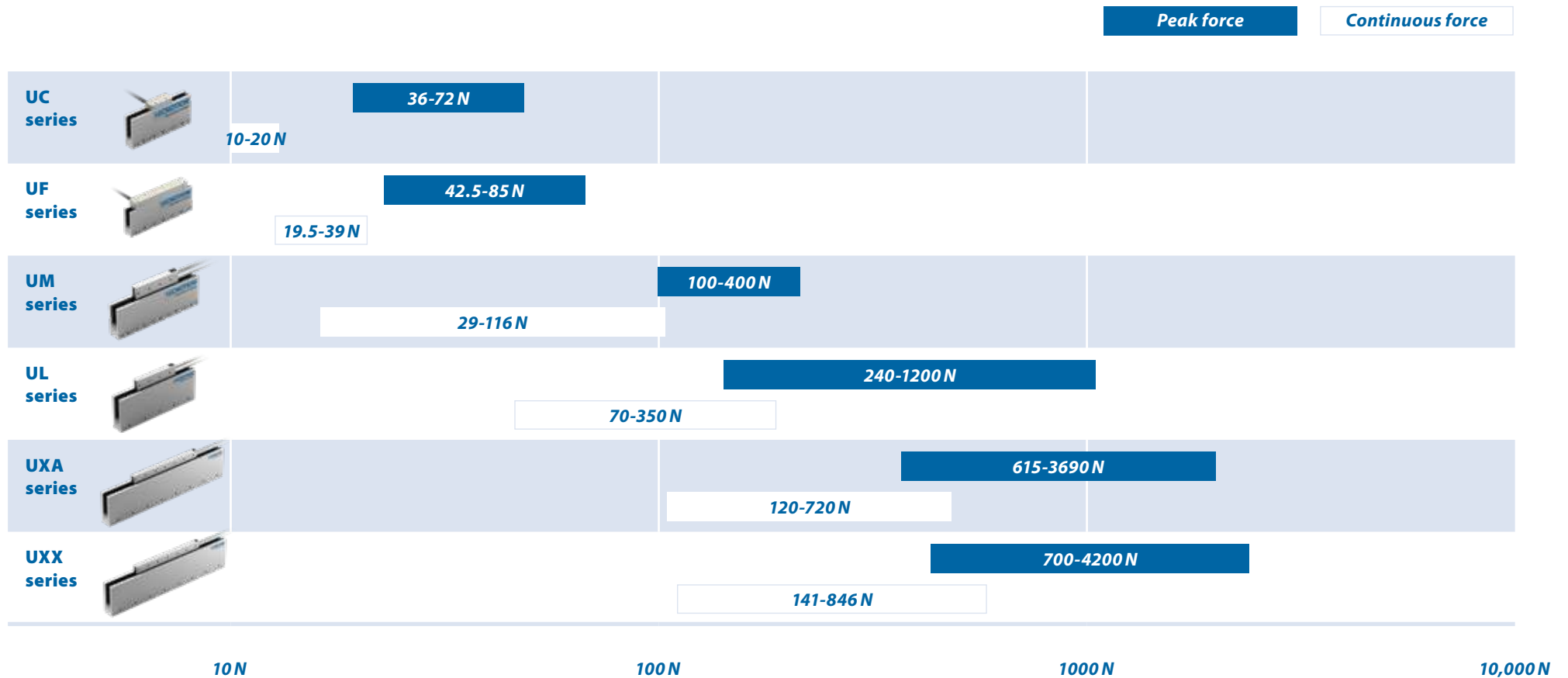

Modular Motor configurations

The direct drive technology of ironless linear motors is a perfect way to enhance productivity. There is no attraction force or cogging between the coil unit and the magnet track. This gives ironless motors their light weight, superior precision, a linear force constant, and extremely dynamic velocity, acceleration, and deceleration.

Motors can be mechanically aligned in series or parallel. This allows motors to move on different tracks, distributing even force to a large gantry, or on the same yoke track, enhancing power along a single line. In both cases, the total force of all motors adds up. Standardizing coil assemblies across multiple machines and applications reduces expenses and simplifies field support.

MODULAR SYSTEM All motors can be used in various configurations

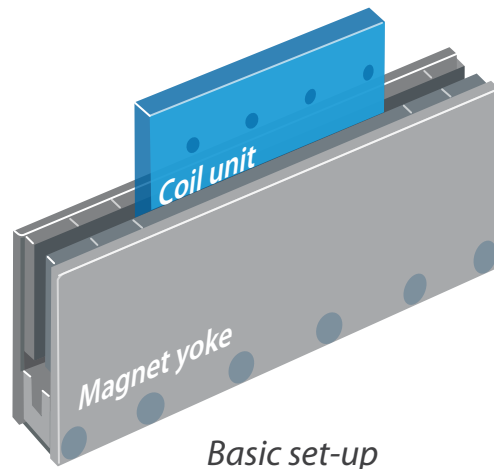

Basic set-up

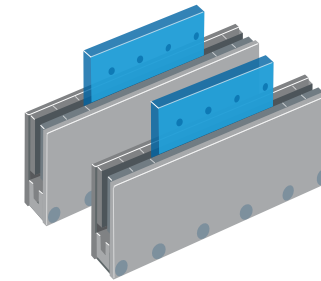

Parallel coupled coil

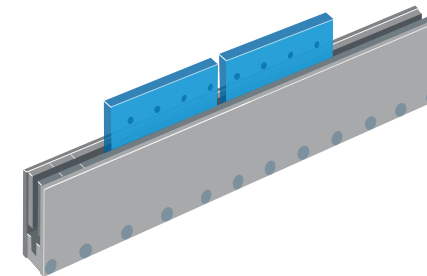

In-line on a single yoke

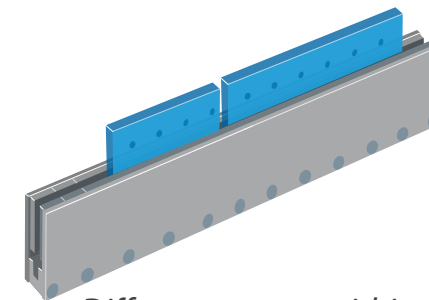

Different motors within one series



UC3 in 99mm magnet yoke shown

UC series ironless

Parameter	Remarks	Symbol	Unit	UC3 + UC3 inline	UC6	
Performance	Motor type, max voltage ph-ph	3-phase synchronous	U_{max}	$V_{ac,rms}$ (V_{dc})	45 (60)	
	Peak force @ 20 K/s increase	magnets @ 25°C	F_p	N	36	72
	Continuous force ¹	coils @ 80°C	F_c	N	10	20
	Maximum speed ²	@ U_{max} @ F_c	v_{max}	m/s	5.0	
	Motor force constant	$I \leq I_c$	K_f	N/A _{rms}	11.4	
	Motor constant	coils @ 25°C	S	N ² /W	9.2	18.1
Electrical	Peak current	magnets @ 25°C	I_p	A _{rms}	3.1	6.2
	Continuous current ¹	coils @ 80°C	I_c	A _{rms}	0.87	1.75
	Back EMF ph-ph _{peak}		K_e	$V_{dc}/m/s$	9.3	
	Resistance per phase	coils @ 25°C ex. cable	R_{ph}	Ω	4.7	2.4
	Induction per phase		L_{ph}	mH	0.75	0.38
	Electrical time constant		τ_e	ms	0.16	
Thermal	Continuous power loss ¹	coils @ 80°C	P_c	W	13	26
	Thermal resistance	coils to mount. sfc.	R_{th}	K/W	3.6	1.8
	Thermal time constant	up to 63% max. coil temp.	τ_{th}	s	25	
	Temperature sensor				none	
Mechanical	Coil unit mass	ex. cables	m	kg	0.031	0.062
	Coil unit length	ex. cables	L	mm	34	67
	Motor attraction force	rms @ 0 A	F_a	N	0	
	Magnet pitch NN		τ	mm	16.5	
	Cable mass			kg/m	0.07	
	Cable type (power)	length 1 m	d	mm (AWG)	4.3 (24)	
	Cable type (sensor)		d	mm (AWG)	none	
	Cable life (power FLEX) ³	minimum		cycles	15,000,000	
Bending radius static (power FLEX)	minimum			5x cable diameter		
Bending radius dynamic (power FLEX)	minimum			8x cable diameter		

All specifications ±10%

Magnet yoke dimensions

Le (mm)	66	99	264
M4 bolts	2	3	8
Mass (kg/m)	3.2		

Magnet yokes can be butted together.

Approvals



¹ These values are only applicable when the mounting surface is at 20°C and the motor is driven at continuous current. If these values differ in your application, please check our simulation tool.

² Actual values depend on bus voltage. Please check the F/v diagram in our simulation tool.

³ Depending on bending radius, velocity and acceleration.

Magnet yokes

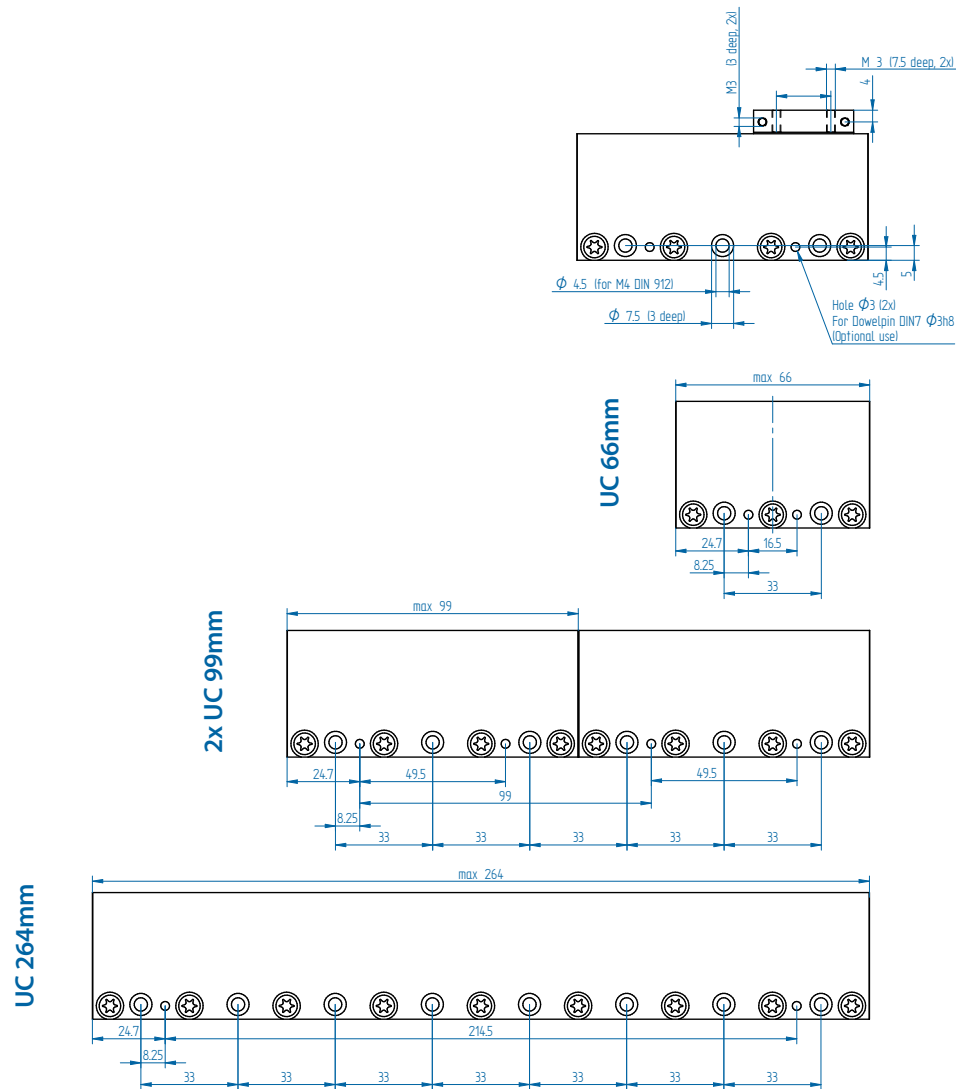

Coil units

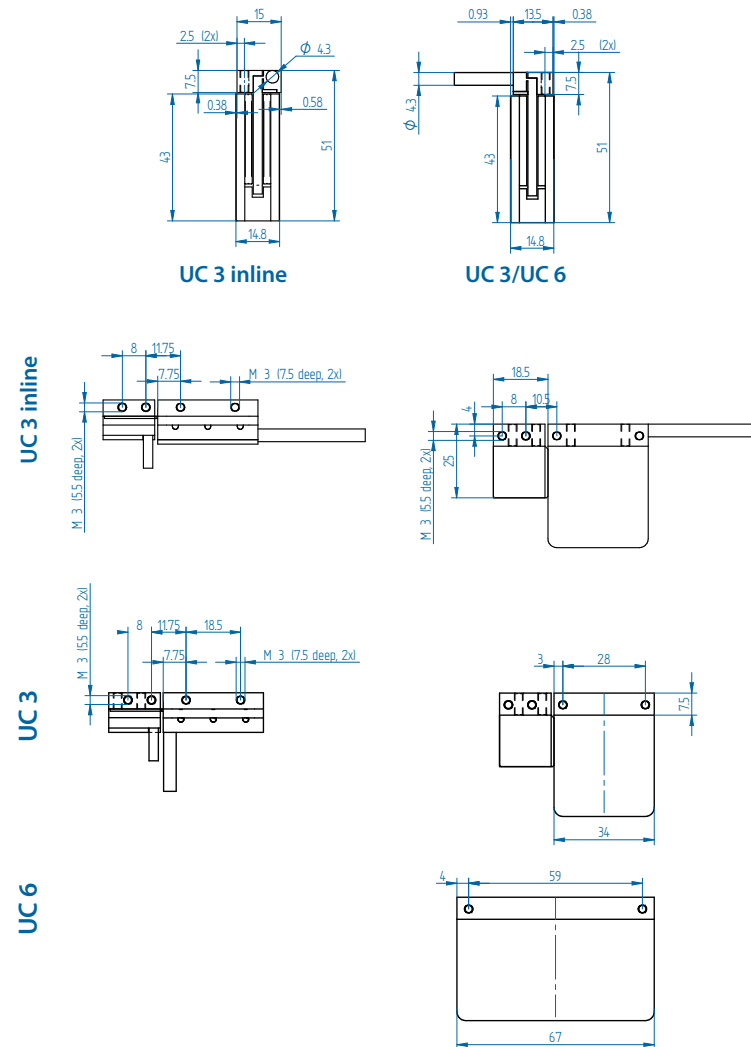

Mounting instructions and flatness or parallelism requirements can be found in the ironless installation manual. CAD files and 3D models can be downloaded from our website.

* All sizes are in mm



UF6 in 120mm magnet yoke shown

UF series ironless

Parameter	Remarks	Symbol	Unit	UF3	UF6	
Performance	Motor type, max voltage ph-ph	3-phase synchronous	U_{max}	$V_{ac,rms}$ (V_{dc})	45 (60)	
	Peak force @ 20 K/s increase	magnets @ 25°C	F_p	N	42.5	85
	Continuous force ¹	coils @ 110°C	F_c	N	19.5	39
	Maximum speed ²	@ U_{max} @ F_c	v_{max}	m/s	5.1	
	Motor force constant	$l \leq l_c$	K_f	N/A _{rms}	12.3	
	Motor constant	coils @ 25°C	S	N ² /W	14.4	28.0
Electrical	Peak current	magnets @ 25°C	I_p	A _{rms}	3.5	6.9
	Continuous current ¹	coils @ 110°C	I_c	A _{rms}	1.58	3.17
	Back EMF ph-ph _{peak}		K_e	$V_{dc}/m/s$	10.1	
	Resistance per phase	coils @ 25°C ex. cable	R_{ph}	Ω	3.5	1.8
	Induction per phase		L_{ph}	mH	1.24	0.62
Electrical time constant		τ_e	ms	0.36		
Thermal	Continuous power loss ¹	coils @ 110°C	P_c	W	35	70
	Thermal resistance	coils to mount. sfc.	R_{th}	K/W	2.4	1.2
	Thermal time constant	up to 63% max. coil temp.	τ_{th}	s	34	
	Temperature sensor				NTC	
Mechanical	Coil unit mass	ex. cables	m	kg	0.045	0.087
	Coil unit length	ex. cables	L	mm	49	97
	Motor attraction force	rms @ 0 A	F_a	N	0	
	Magnet pitch NN		τ	mm	24	
	Cable mass			kg/m	0.07	
	Cable type (power and sensor)	length 1 m	d	mm (AWG)	4.3 (24)	
	Cable life (FLEX) ³	minimum		cycles	15,000,000	
	Bending radius static	minimum			5x cable diameter	
Bending radius dynamic	minimum			8x cable diameter		

Magnet yoke dimensions

Le (mm)	72	120
M4 bolts	2	3
Mass (kg/m)	3.2	

Magnet yokes can be butted together.

Approvals



¹ These values are only applicable when the mounting surface is at 20°C and the motor is driven at continuous current. If these values differ in your application, please check our simulation tool.

² Actual values depend on bus voltage. Please check the F/v diagram in our simulation tool.

³ Depending on bending radius, velocity and acceleration.

Magnet yokes

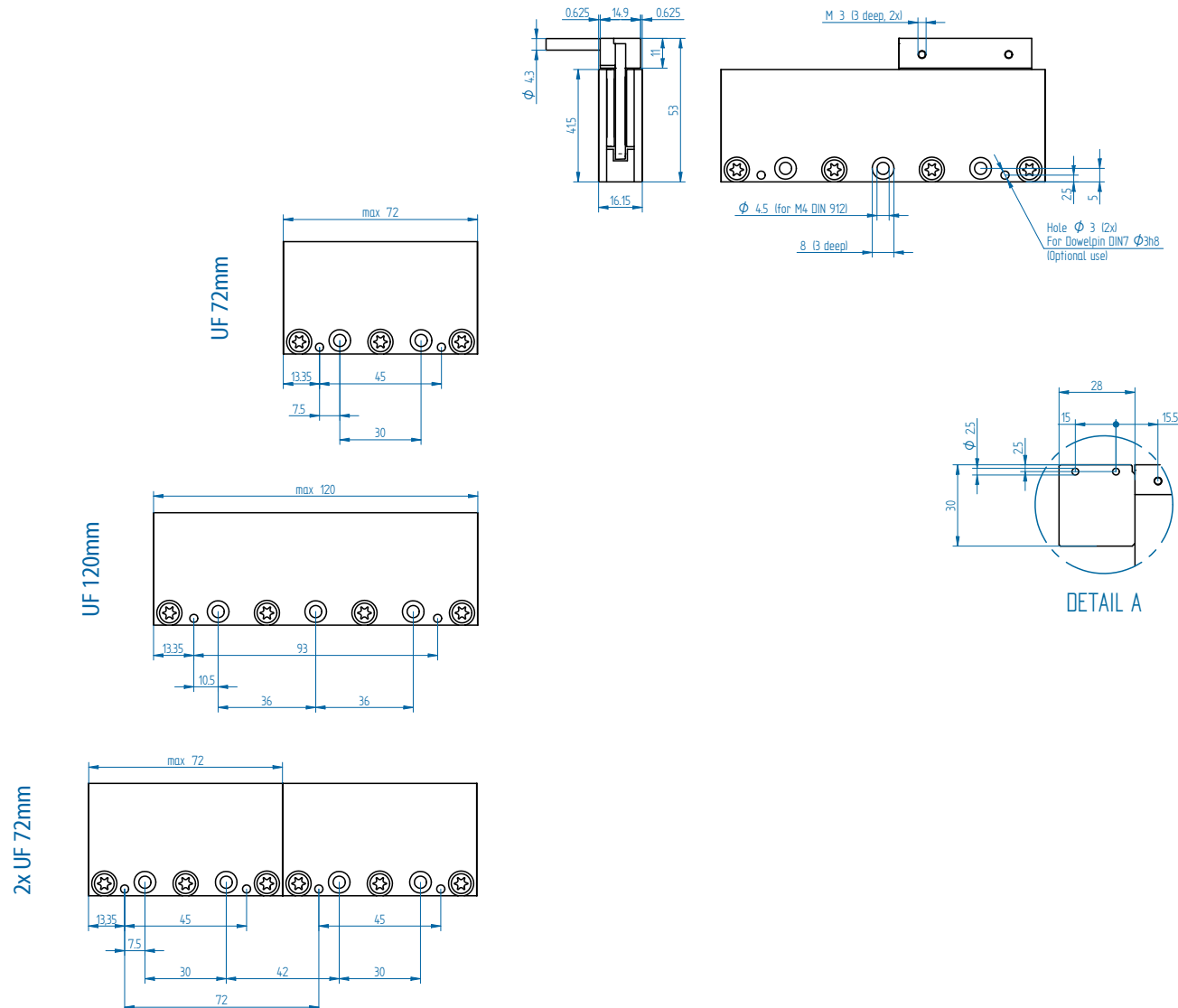

Coil units

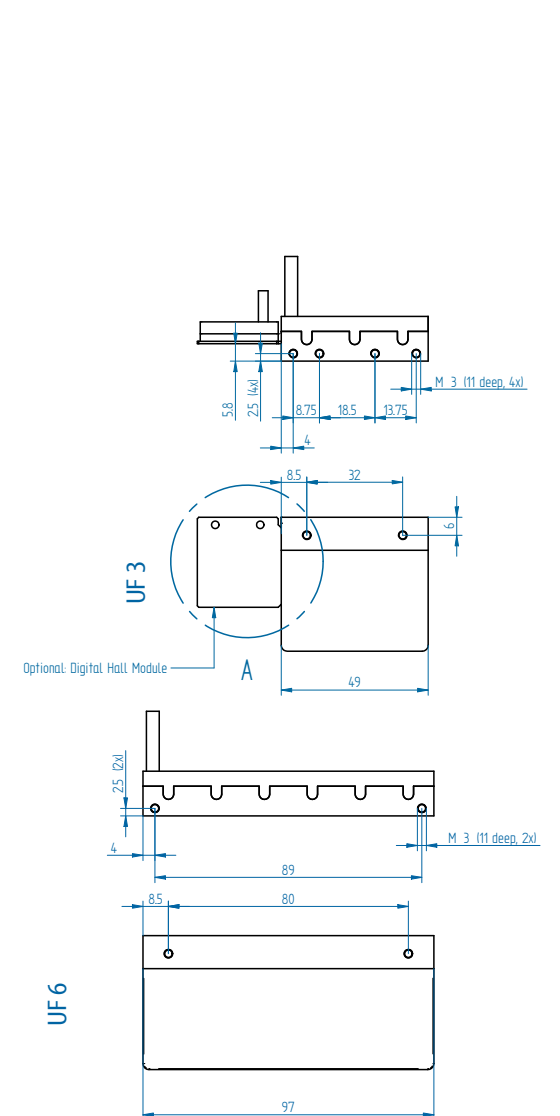

Mounting instructions and flatness or parallelism requirements can be found in the ironless installation manual. CAD files and 3D models can be downloaded from our website.

* All sizes are in mm



UM3 in 150mm magnet yoke shown

UM series ironless

Parameter	Remarks	Symbol	Unit	UM3		UM6		UM9		UM12		
				N	S	N	S	N	S	N	S	
Performance	Winding type			N S N S N S N S								
	Motor type, max voltage ph-ph	3-phase synchronous	U_{max}	$V_{ac,rms}$ (V _{dc})	230 (325)							
	Peak force @ 20 K/s increase	magnets @ 25°C	F_p	N	100		200		300		400	
	Continuous force ¹	coils @ 110°C	F_c	N	29		58		87		116	
	Continuous force ^{1,3}	coils @ 105°C	F_c	N	28		57		85		113	
	Maximum speed ²	@ U_{max} @ F_c	v_{max}	m/s	10	18	10	18	10	18	10	18
	Motor force constant	$I \leq I_c$	K_f	N/A _{rms}	36.3	19.9	36.3	19.9	36.3	19.9	36.3	19.9
	Motor constant	coils @ 25°C	S	N ² /W	24	24	47	47	71	73	95	94
Electrical	Peak current	magnets @ 25°C	I_p	A _{rms}	2.8	5.0	5.5	10	8.3	15	11	20
	Continuous current ¹	coils @ 110°C	I_c	A _{rms}	0.8	1.5	1.6	2.9	2.4	4.4	3.2	5.8
	Continuous current ^{1,3}	coils @ 105°C	I_c	A _{rms}	0.8	1.4	1.6	2.8	2.3	4.2	3.1	5.7
	Back EMF ph-ph _{peak}		K_e	V _{dc} /m/s	30	16	30	16	30	16	30	16
	Resistance per phase	coils @ 25°C ex. cable	R_{ph}	Ω	18.5	5.5	9.3	2.8	6.2	1.8	4.6	1.4
	Induction per phase		L_{ph}	mH	6.5	1.8	3.3	0.9	2.2	0.6	1.5	0.4
	Electrical time constant		τ_e	ms	0.35							
Thermal	Continuous power loss ¹	coils @ 110°C	P_c	W	47		95		142		190	
	Continuous power loss ^{1,3}	coils @ 105°C	P_c	W	44		89		133		178	
	Thermal resistance	coils to mount. sfc.	R_{th}	K/W	1.8		0.9		0.6		0.45	
	Thermal time constant	up to 63% max. coil temp.	τ_{th}	s	36							
	Temperature sensor				PTC 1kΩ / NTC							
Mechanical	Coil unit mass	ex. cables	m	kg	0.100		0.162		0.240		0.318	
	Coil unit length	ex. cables	L	mm	78		138		198		258	
	Motor attraction force	rms @ 0 A	F_a	N	0							
	Magnet pitch NN		τ	mm	30							
	Cable mass			kg/m	0.08							
	Cable type (power)	length 1 m	d	mm (AWG)	5.5 (22)							
	Cable type (sensor)	length 1 m	d	mm (AWG)	3.2 (26)							

Magnet yoke dimensions

Le (mm)	90	120	150	390
M4 bolts	3	4	5	13
Mass (kg/m)	4.8			

Magnet yokes can be butted together.

Approvals



All specifications ±10%

¹ These values are only applicable when the mounting surface is at 20°C and the motor is driven at continuous current. If these values differ in your application, please check our simulation tool.

² Actual values depend on bus voltage. Please check the F/v diagram in our simulation tool.

³ The maximum coil temperature for CSA certification is 105°C. The maximum coil temperature without CSA certification is 110°C.

Magnet yokes

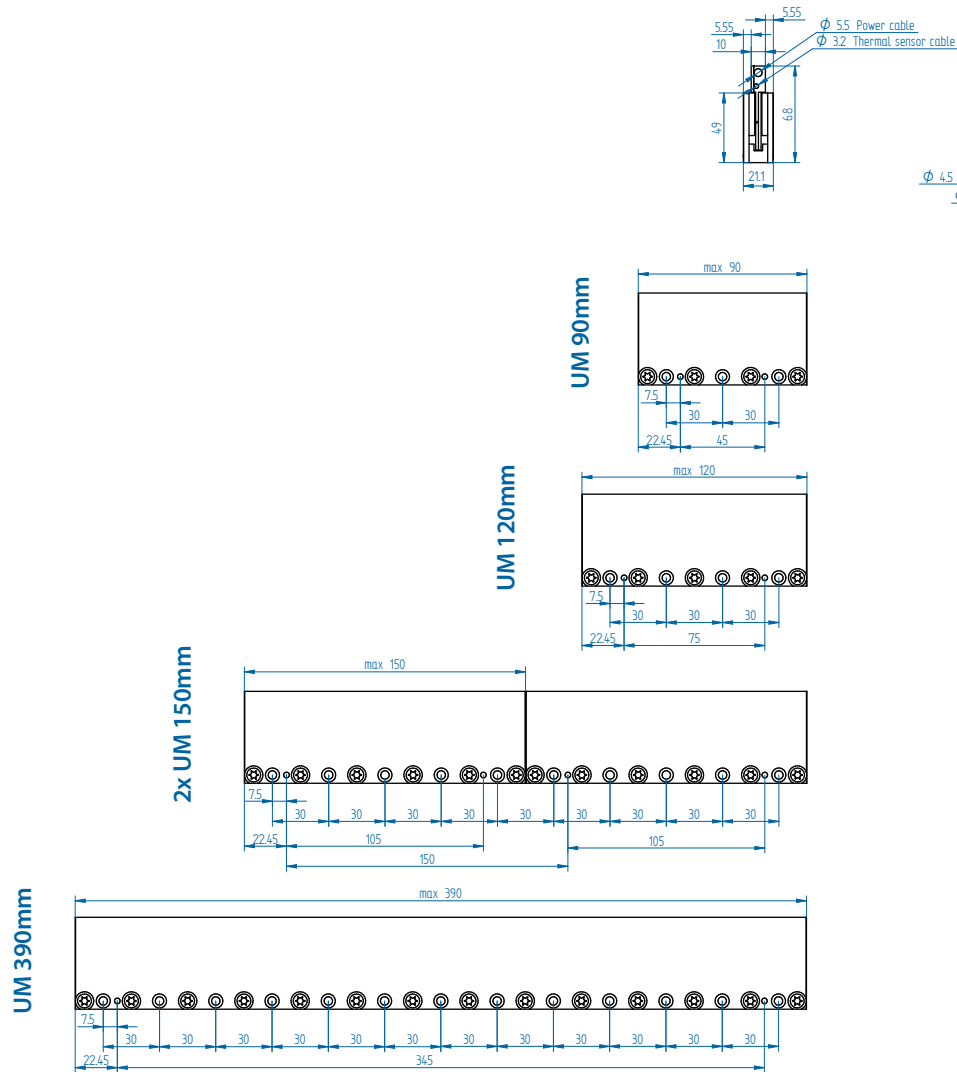

Coil units

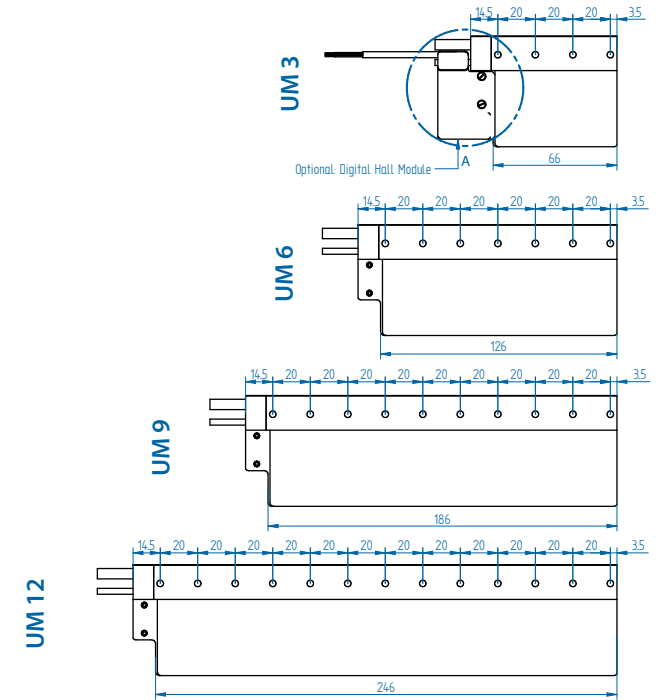
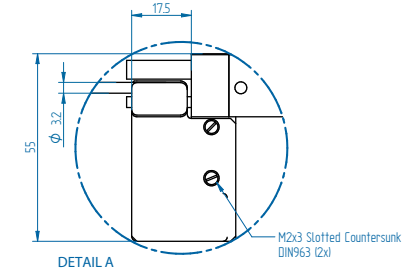
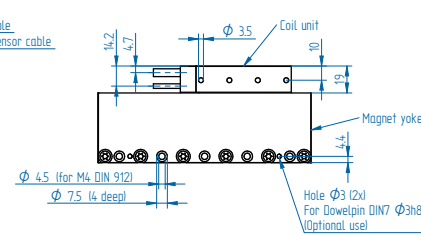

Mounting instructions and flatness or parallelism requirements can be found in the ironless installation manual. CAD files and 3D models can be downloaded from our website.

* All sizes are in mm



UL3 in 210mm magnet yoke shown

UL series ironless

Parameter		Remarks	Symbol	Unit	UL3		UL6		UL9		UL12		UL15	
					N	S	N	S	N	S	N	S	N	S
Performance	Winding type				N S		N S		N S		N S		N S	
	Motor type, max voltage ph-ph	3-phase synchronous	U_{max}	$V_{ac,rms} (V_{dc})$	230 (325)									
	Peak force @ 20 K/s increase	magnets @ 25°C	F_p	N	240		480		720		960		1200	
	Continuous force ¹	coils @ 110°C	F_c	N	70		140		210		280		350	
	Continuous force ^{1,3}	coils @ 105°C	F_c	N	67		137		201		269		336	
	Maximum speed ²	@ $U_{max} @ F_c$	v_{max}	m/s	5.0	12	5.0	12	5.0	12	5.0	12	5.0	12
	Motor force constant	$I \leq I_c$	K_f	N/A _{rms}	68	27.5	68	27.5	68	27.5	68	27.5	68	27.5
	Motor constant	coils @ 25°C	S	N ² /W	97	97	193	197	291	297	385	394	460	476
Electrical	Peak current	magnets @ 25°C	I_p	A _{rms}	3.5	8.7	7.1	17.5	10.6	26.2	14.1	35	17.8	44
	Continuous current ¹	coils @ 110°C	I_c	A _{rms}	1.0	2.6	2.1	5.1	3.1	7.6	4.2	10.2	5.2	12.9
	Continuous current ^{1,3}	coils @ 105°C	I_c	A _{rms}	1.0	2.5	2.0	4.9	3.0	7.4	4.0	9.9	4.9	12.3
	Back EMF ph-ph _{peak}		K_e	$V_{dc}/m/s$	55.5	22.5	55.5	22.5	55.5	22.5	55.5	22.5	55.5	22.5
	Resistance per phase	coils @ 25°C ex. cable	R_{ph}	Ω	15.9	2.6	8.0	1.28	5.3	0.85	4.0	0.64	3.3	0.53
	Induction per phase		L_{ph}	mH	13	2.1	6.5	1.02	4.2	0.68	3.2	0.51	2.7	0.42
	Electrical time constant		τ_e	ms	0.8									
Thermal	Continuous power loss ¹	coils @ 110°C	P_c	W	67		134		200		270		335	
	Continuous power loss ^{1,3}	coils @ 105°C	P_c	W	62		123		185		246		308	
	Thermal resistance	coils to mount. sfc.	R_{th}	K/W	1.3		0.65		0.43		0.32		0.26	
	Thermal time constant	up to 63% max. coil temp.	τ_{th}	s	72									
	Temperature sensor				PTC 1kΩ / NTC									
Mechanical	Coil unit mass	ex. cables	m	kg	0.27		0.49		0.69		0.91		1.13	
	Coil unit length	ex. cables	L	mm	106		190		274		358		442	
	Motor attraction force	rms @ 0 A	F_a	N	0									
	Magnet pitch NN		τ	mm	42									
	Cable mass			kg/m			0.09				0.105			
	Cable type (power)	length 1 m	d	mm (AWG)			5.9 (20)				6.4 (18)			
Cable type (sensor)	length 1 m	d	mm (AWG)					4.7 (26)						

Magnet yoke dimensions

Le (mm) 126 168 210 546

M5 bolts 3 4 5 13

Mass (kg/m) 11.2

Magnet yokes can be butted together.

Approvals



All specifications ±10%

¹ These values are only applicable when the mounting surface is at 20°C and the motor is driven at continuous current. If these values differ in your application, please check our simulation tool.

² Actual values depend on bus voltage. Please check the F/v diagram in our simulation tool.

³ The maximum coil temperature for CSA certification is 105°C. The maximum coil temperature without CSA certification is 110°C.

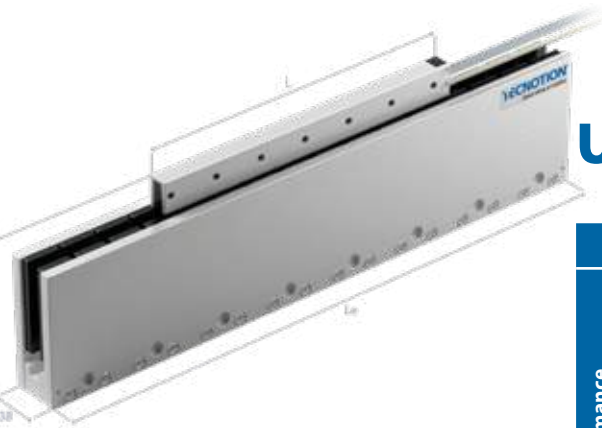

UXA series ironless

UXA6 in 456mm magnet yoke shown

UXA3S power cable (FLEX cable of 3m)

Cable type	8.5 mm (21 AWG)
Cable life ⁵	5,000,000 cycles
Bending radius static	4x cable diameter
Bending radius dynamic	10x cable diameter

⁵ Depending on bending radius, velocity and acceleration.

Magnet yoke dimensions

Le (mm)	114	171	456
M6 bolts	2	3	8
Mass (kg/m)	19		

Magnet yokes can be butted together.

Approvals



Parameter	Remarks	Symbol	Unit	UXA3		UXA6		UXA9		UXA12		UXA18	
				N	S	N	S	N	S	N	S	N	
Performance	Winding type			N S N S N S N S N									
Motor type, max voltage ph-ph	3-phase synchronous	U_{max}	$V_{ac,rms} (V_{dc})$	230 (325)									
Peak force @ 20 K/s increase	magnets @ 25°C	F_p	N	615		1230		1845		2460		3690	
Continuous force ¹	coils @ 110°C	F_c	N	120		240		360		480		720	
Continuous force ^{1,3}	coils @ 105°C	F_c	N	119		239		358		477		716	
Maximum speed ²	@ $U_{max} @ F_c$	v_{max}	m/s	2.9	7.2	2.9	7.2	2.9	7.2	2.9	7.2	2.9	
Motor force constant	$I \leq I_c$	K_f	N/A _{rms}	107	43.4	107	43.4	107	43.4	107	43.4	107	
Motor constant	coils @ 25°C	S	N ² /W	242	241	483	487	720	730	954	966	1468	
Electrical	Peak current	magnets @ 25°C	I_p	A _{rms}	5.6	13.9	11.3	28	16.9	42	22.6	56	34
Continuous current ¹	coils @ 110°C	I_c	A _{rms}	1.1	2.8	2.3	5.6	3.4	8.4	4.5	11.2	6.8	
Continuous current ^{1,3}	coils @ 105°C	I_c	A _{rms}	1.1	2.7	2.2	5.5	3.3	8.2	4.5	10.9	6.7	
Back EMF ph-ph _{peak}		K_e	V _{dc} /m/s	87	35	87	35	87	35	87	35	87	
Resistance per phase	coils @ 25°C ex. cable	R_{ph}	Ω	15.8	2.6	7.9	1.29	5.3	0.86	4.0	0.65	2.6	
Induction per phase		L_{ph}	mH	28	4.6	14	2.3	9.5	1.5	7.1	1.2	4.7	
Electrical time constant		τ_e	ms	1.8									
Thermal	Continuous power loss ¹	coils @ 110°C	P_c	W	82		165		247		330		494
Continuous power loss ^{1,3}	coils @ 105°C	P_c	W	77		154		231		308		462	
Thermal resistance	coils to mount. sfc.	R_{th}	K/W	1.04		0.52		0.35		0.26		0.17	
Thermal time constant	up to 63% max. coil temp.	τ_{th}	s	156									
Temperature sensor				PTC 1kΩ / NTC									
Mechanical	Coil unit mass	ex. cables	m	kg	0.55		1.06		1.55		2.06		3.02
Coil unit length	ex. cables	L	mm	134		248		362		476		704	
Motor attraction force	rms @ 0 A	F_a	N	0									
Magnet pitch NN		τ	mm	57									
Cable mass			kg/m	0.105									
Cable type (power) ⁴	length 1 m	d	mm (AWG)	6.5 (18)									
Cable type (sensor)	length 1 m	d	mm (AWG)	4.7 (26)									

All specifications ±10%

¹ These values are only applicable when the mounting surface is at 20°C and the motor is driven at continuous current. If these values differ in your application, please check our simulation tool.

² Actual values depend on bus voltage. Please check the F/v diagram in our simulation tool.

³ The maximum coil temperature for CSA certification is 105°C. The maximum coil temperature without CSA certification is 110°C.

⁴ The UXA3S is only available with a FLEX power cable.

Magnet yokes

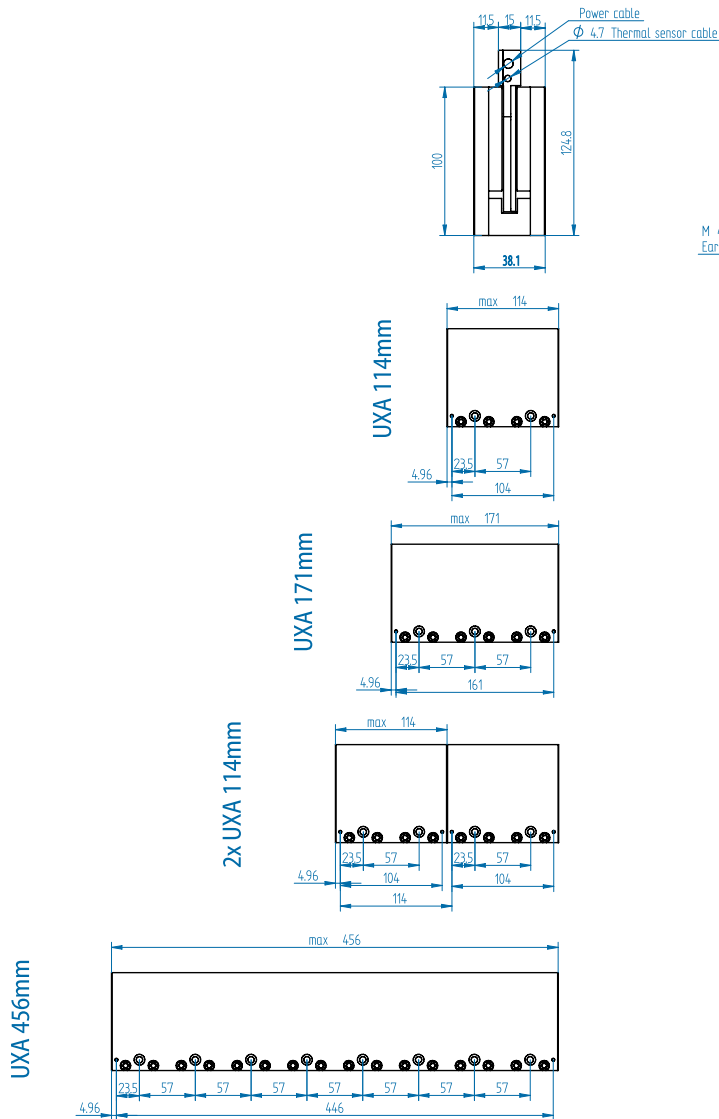

Coil units

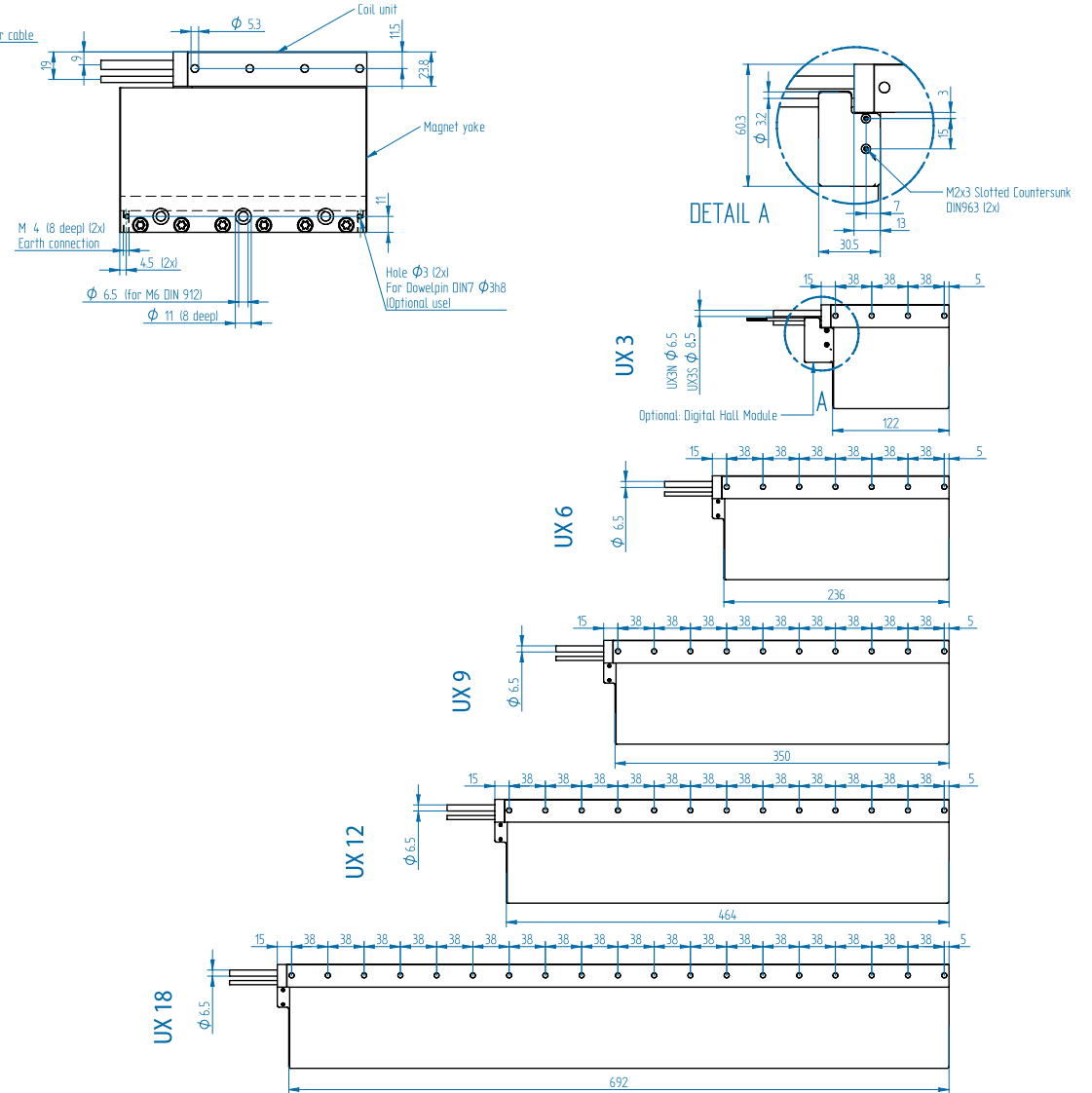

Mounting instructions and flatness or parallelism requirements can be found in the ironless installation manual. CAD files and 3D models can be downloaded from our website.

* All sizes are in mm

UXX series ironless

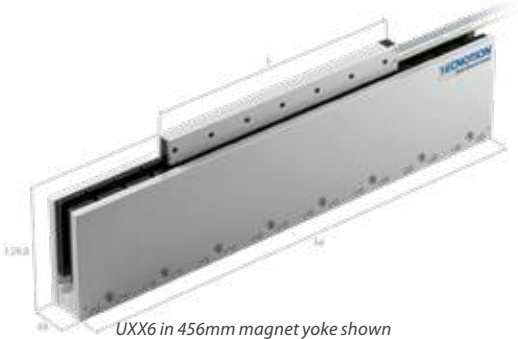

UXX6 in 456mm magnet yoke shown

UXX3S power cable (FLEX cable of 3m)

Cable type	8.5 mm (21 AWG)
Cable life ⁵	5,000,000 cycles
Bending radius static	4x cable diameter
Bending radius static	10x cable diameter

⁵ Depending on bending radius, velocity and acceleration.

Magnet yoke dimensions

Le (mm)	114	171	456
M6 bolts	2	3	8
Mass (kg/m)	25		

Magnet yokes can be butted together.

Approvals



Parameter	Remarks	Symbol	Unit	UXX3		UXX6		UXX9		UXX12		UXX18
				N	S	N	S	N	S	N	S	N
Performance												
Winding type				N	S	N	S	N	S	N	S	N
Motor type, max voltage ph-ph	3-phase synchronous	U_{max}	$V_{ac,rms} (V_{dc})$	230 (325)								
Peak force @ 20 K/s increase	magnets @ 25°C	F_p	N	700		1400		2100		2800		4200
Continuous force ¹	coils @ 110°C	F_c	N	141		282		423		564		846
Continuous force ^{1,3}	coils @ 105°C	F_c	N	138		277		415		553		830
Maximum speed ²	@ U_{max} @ F_c	v_{max}	m/s	2.7	6.6	2.7	6.6	2.7	6.6	2.7	6.6	2.7
Motor force constant	$l \leq l_c$	K_f	N/A _{rms}	124	50.3	124	50.3	124	50.3	124	50.3	124
Motor constant	coils @ 25°C	S	N ² /W	324	324	649	654	967	981	1281	1297	1971
Electrical												
Peak current	magnets @ 25°C	I_p	A _{rms}	5.6	13.9	11.3	28	16.9	42	22.6	56	34
Continuous current ¹	coils @ 110°C	I_c	A _{rms}	1.1	2.8	2.3	5.6	3.4	8.4	4.5	11.2	6.8
Continuous current ^{1,3}	coils @ 105°C	I_c	A _{rms}	1.1	2.7	2.2	5.5	3.3	8.2	4.5	10.9	6.7
Back EMF ph-ph _{peak}		K_e	V _{dc} /m/s	101	41	101	41	101	41	101	41	101
Resistance per phase	coils @ 25°C ex. cable	R_{ph}	Ω	15.8	2.6	7.9	1.29	5.3	0.86	4.0	0.65	2.6
Induction per phase		L_{ph}	mH	28	4.6	14	2.3	9.5	1.5	7.1	1.2	4.7
Electrical time constant		τ_e	ms	1.8								
Thermal												
Continuous power loss ¹	coils @ 110°C	P_c	W	82		165		247		330		494
Continuous power loss ^{1,3}	coils @ 105°C	P_c	W	77		154		231		308		462
Thermal resistance	coils to mount. sfc.	R_{th}	K/W	1.04		0.52		0.35		0.26		0.17
Thermal time constant	up to 63% max. coil temp.	τ_{th}	s	156								
Temperature sensor				PTC 1kΩ / NTC								
Mechanical												
Coil unit mass	ex. cables	m	kg	0.55		1.06		1.55		2.06		3.02
Coil unit length	ex. cables	L	mm	134		248		362		476		704
Motor attraction force	rms @ 0 A	F_a	N	0								
Magnet pitch NN		τ	mm	57								
Cable mass			kg/m	0.105								
Cable type (power) ⁴	length 1 m	d	mm (AWG)	6.5 (18)								
Cable type (sensor)	length 1 m	d	mm (AWG)	4.7 (26)								

¹ These values are only applicable when the mounting surface is at 20°C and the motor is driven at continuous current. If these values differ in your application, please check our simulation tool.

² Actual values depend on bus voltage. Please check the F/v diagram in our simulation tool.

³ The maximum coil temperature for CSA certification is 105°C. The maximum coil temperature without CSA certification is 110°C.

⁴ The UXX3S is only available with a FLEX power cable.

All specifications ±10%

Magnet yokes

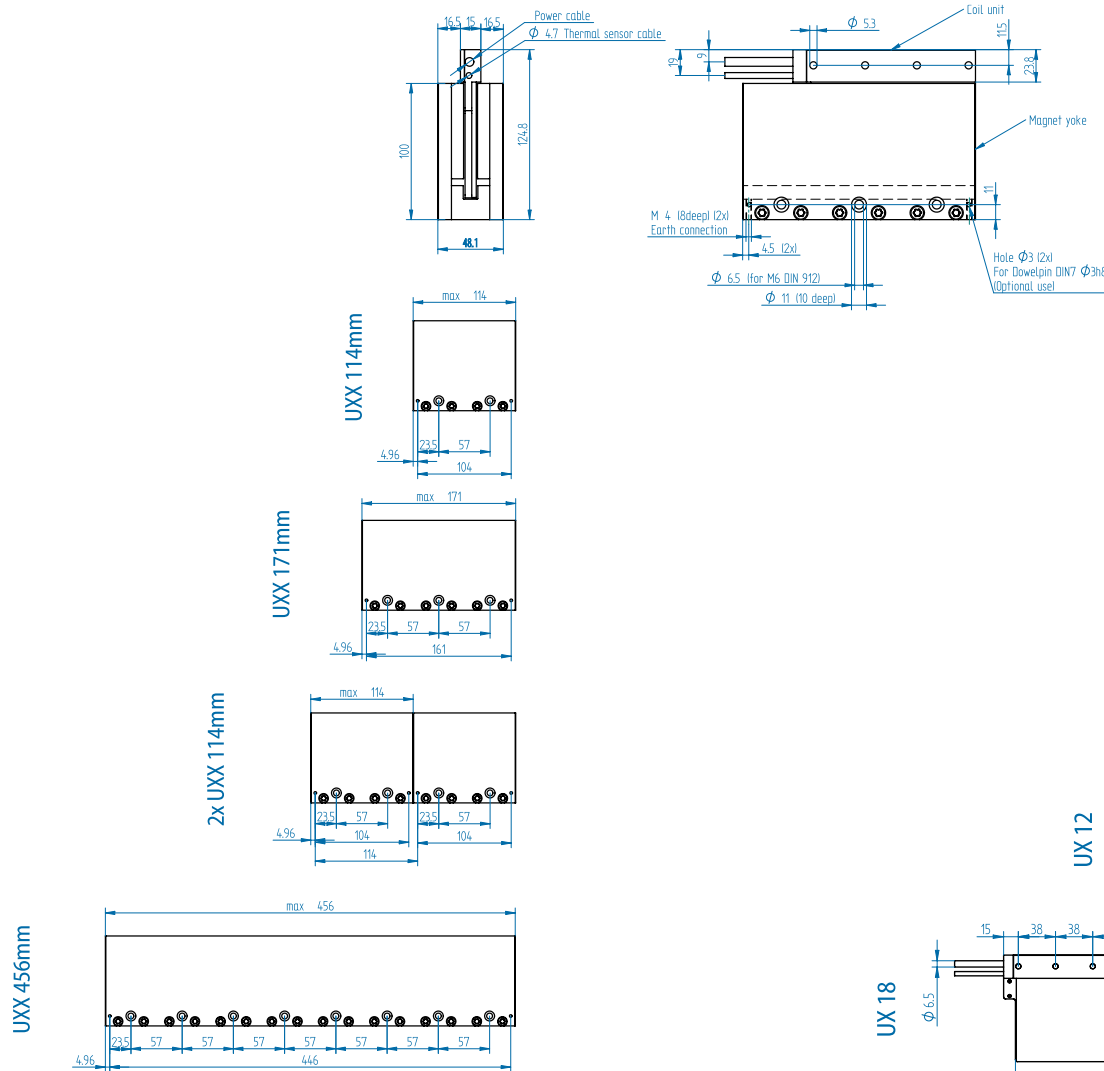

Coil units

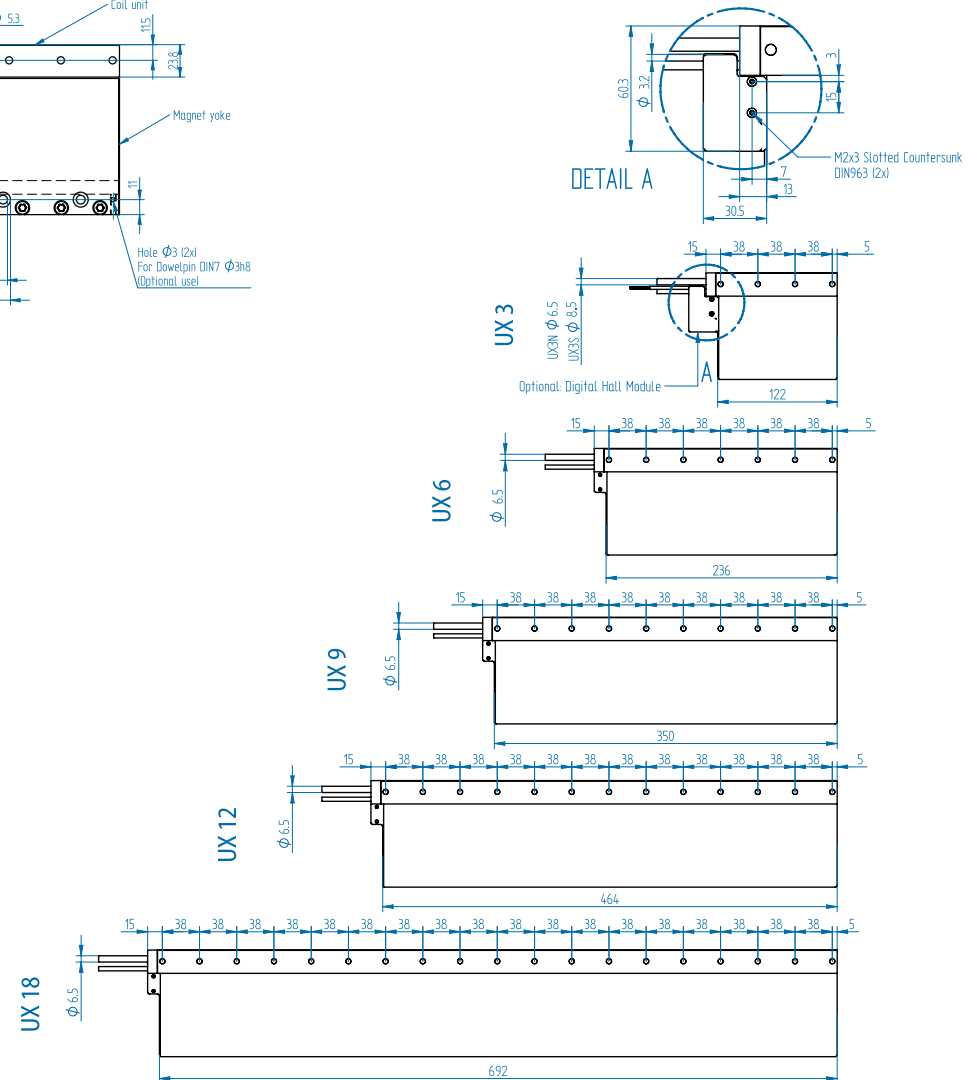

Mounting instructions and flatness or parallelism requirements can be found in the ironless installation manual. CAD files and 3D models can be downloaded from our website.

* All sizes are in mm

Digital Hall module for commutation

Digital Hall sensors can be used to determine the position of the coil unit within the magnetic field for a controller to correctly commutate the phases. If you do not use a controller that allows you to commutate within the servo drive, this module can be a cost-effective alternative.

Each ironless motor series has its own additional digital Hall module. Resolutions of the digital Hall modules are: UC: 2.75 mm; UF: 4 mm; UM: 5 mm; UL: 7 mm; UXA/UXX: 9.5 mm.

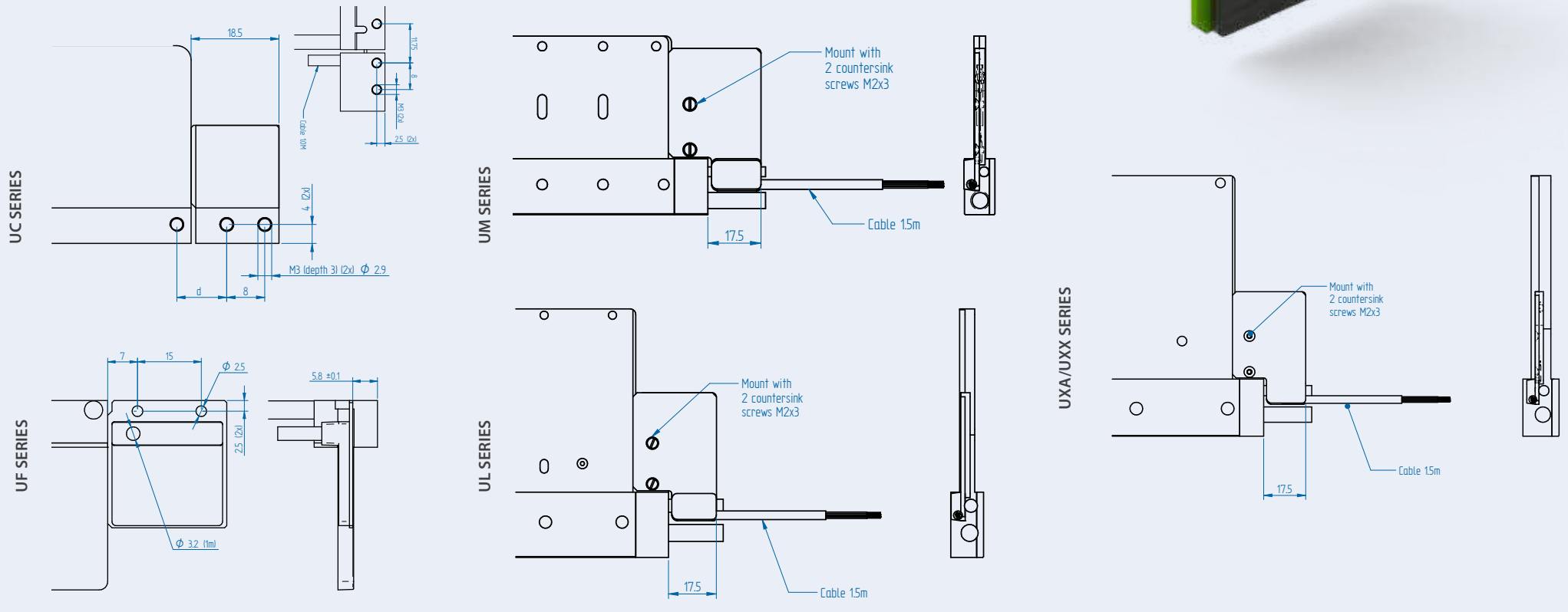
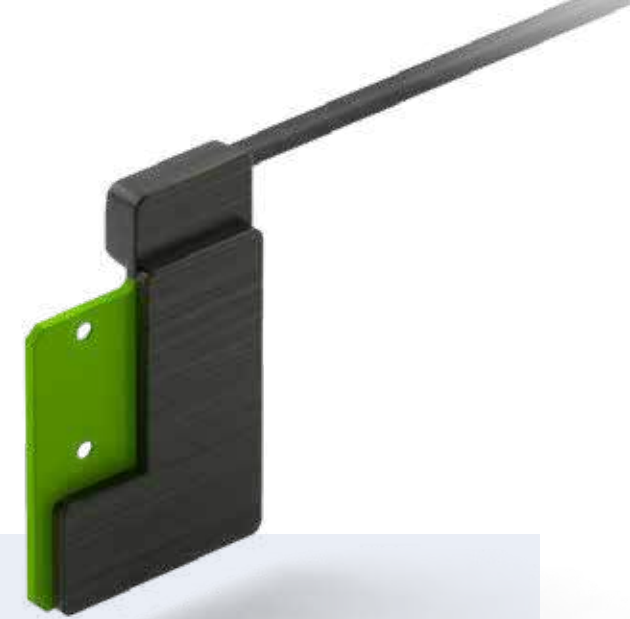

Mounting instructions and flatness or parallelism requirements can be found in the iron core installation manual. CAD files and 3D models can be downloaded from our website.

Support

At Tecnotion, we recognize that every use of our motors presents unique circumstances with different needs and challenges. Our team of Sales and Application Engineers have extensive experience in different application scenarios and work closely with our customers to find solutions that perfectly align with their requirements and objectives.

With our commitment to excellence and innovation, we remain steadfast in our mission to provide our customers with solutions that lead them to success in an ever-changing landscape.

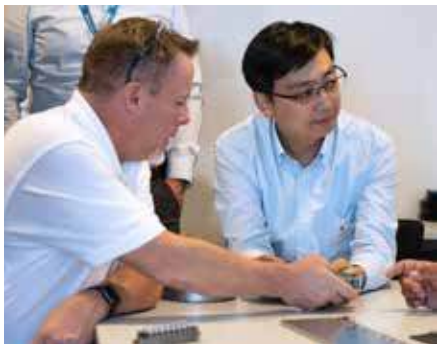

Continuous innovation

At the heart of our company is an internal Research and Development (R&D) department that serves as an engine for innovation. This dedication to innovation not only fuels our deep knowledge of manufacturing processes, but also drives our commitment to excel in product design and performance, helping our customers meet the changing needs and expectations of their customers.

In addition to our extensive range of off-the-shelf standard motors, we custom design motors for applications that have more unique requirements. Our team works closely with customers to understand their specific challenges and objectives.



Modern manufacturing

Our manufacturing capabilities are strategically distributed between our facilities in China, Vietnam and the Netherlands, each of which plays a vital role in delivering first-class products to our customers worldwide. This distribution enables us to meet the demands of mass production.

Our competence centre and headquarters in the Netherlands are dedicated to advanced motor technology and are the epicentre of innovation and precision engineering. Custom motors are also built here in our special state-of-the-art clean room environment, with extreme precision and an eye for quality. Tecnotion prides itself on maintaining the strictest quality standards in all facets of our operations. Our plants are ISO 9001 certified.



Global logistics

We ensure that our most popular products are in stock in our warehouses. This setup gives us quick access to our stock, regardless of your location. Whether you are near our European headquarters or on the other side of the world, our efficient shipping network ensures that your orders are processed quickly.

Even during periods of increased market activity, our flexible supply chain allows us to maintain fast delivery times, so your products reach you quickly and reliably. With our unwavering commitment to customer satisfaction and operational excellence, we strive to provide seamless and efficient service throughout the supply chain.



We direct drive your motion technology

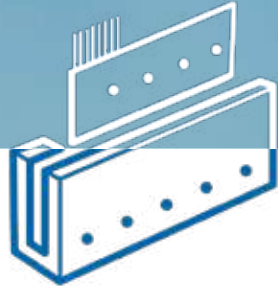

Vacuum linear motors

F_p 100-4020 N F_c 22-698 N

Vacuum Generation 2 motors for powerful and precise processes
Generation 2 vacuum ironless linear motor series is designed with the unique challenges of vacuum applications in mind and based on years of collaboration with high-end semiconductor manufacturers.

Optimal thermal properties, added safety, excellent RGA performance, lower outgassing and flexibility to install, make the Generation 2 vacuum motor series the benchmark for motion in vacuum applications.

www.tecnotion.com/vacuum



Torque motors

T_u 0.64-2202 Nm T_c 0.29-907 Nm

Increased accuracy and dynamic performance of your application
Tecnotion torque motor series features superior force density, low thermal resistance, low cogging and housed design. Motors can be very slim in height but large in diameter (for large axles and turntables) or have a 'height' close to their diameter, resulting in a compact but high-torque motor.

The torque series consists of different outer diameters ranging from 65mm to 485mm for the largest motor and various building heights ranging from 17mm up to 105mm.

www.tecnotion.com/torque



Custom motors

Motor solutions

Adapt standard motor series to meet your needs

In case the standard motor series are not sufficient for your application, it is also possible to have these motors customized in a variety of ways. Customization can range from simple modifications, like adding a connector, to fully tailor-made motors designed from scratch.

Some examples: custom windings, cable confection, additional sensors, additional certifications and customization for vacuum applications. For more information please contact Tecnotion.

www.tecnotion.com/custom

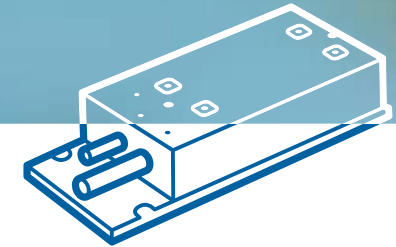

Iron core linear motors

F_u 120-6750 N F_c 60-3000 N

Extremely high force in a modular compact design

Designed and constructed with an iron core, these series offer an extremely high continuous force for their size, starting at 60 N for the small TM, up to 3000 N for the water cooled TBW. Peak forces are even higher, reaching up to 6000 N.

A small footprint, modular design, and high force density enable very flexible application designs, using iron core linear motors. Suitable for many applications such as printing, digital cutting, and machine tooling.

www.tecnotion.com/ironcore



Motor simulation tool

Analyze your application

Size your application with the motor selection and simulation tool

Online motor simulation software helps you find the best motor for the application and generate reports within seconds, without having to make time consuming calculations by hand.

The motor sizing simulation tool helps to select the right torque or linear motor, using your application characteristics. The tool will provide you with diagrams for position, velocity, acceleration, jerk, torque, power, voltage, current, temperature and torque vs. velocity.

www.tecnotion.com/simtool

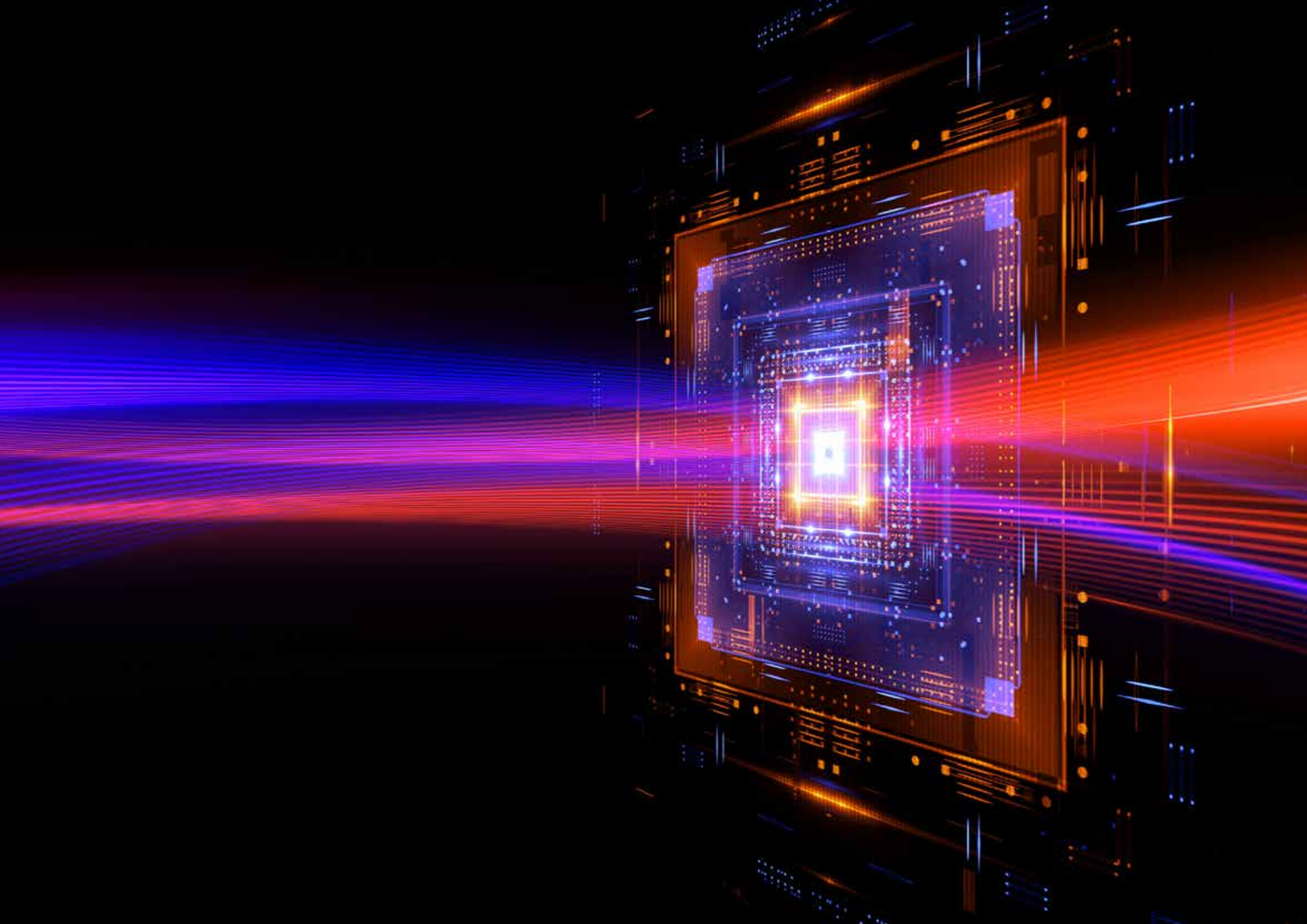

Article numbers

Series	Article	Article code
UC series		
UC	Coil unit UC 3	4022 368 5067
UC	Coil unit UC 3 inline	4022 368 5516
UC	Coil unit UC 6	4022 368 5068
UC	Magnet yoke UC 66 mm	4022 368 5064
UC	Magnet yoke UC 99 mm	4022 368 5065
UC	Magnet yoke UC 264 mm	4022 368 5066
UC	Digital Hall Module UC	4022 368 5130
UF series		
UF	Coil unit UF 3	4022 368 5298
UF	Coil unit UF 6	4022 368 5372
UF	Magnet yoke UF 72 mm	4022 368 5382
UF	Magnet yoke UF 120 mm	4022 368 5383
UF	Digital Hall Module UF	4022 368 5391
UM series		
UM	Coil unit UM 3N	4022 368 5055
UM	Coil unit UM 3S	4022 368 5051
UM	Coil unit UM 6N	4022 368 5056
UM	Coil unit UM 6S	4022 368 5052
UM	Coil unit UM 9N	4022 368 5057
UM	Coil unit UM 9S	4022 368 5053
UM	Coil unit UM 12N	4022 368 5058
UM	Coil unit UM 12S	4022 368 5054
UM	Magnet yoke UM 90 mm	4022 368 5040
UM	Magnet yoke UM 120 mm	4022 368 5041
UM	Magnet yoke UM 150 mm	4022 368 5042
UM	Magnet yoke UM 390 mm	4022 368 5043
UM	Digital Hall Module UM	4022 368 5144
UL series		
UL	Coil unit UL 3N	4022 368 5025
UL	Coil unit UL 3S	4022 368 5045

Series	Article	Article code
UL	Coil unit UL 6N	4022 368 5026
UL	Coil unit UL 6S	4022 368 5046
UL	Coil unit UL 9N	4022 368 5027
UL	Coil unit UL 9S	4022 368 5047
UL	Coil unit UL 12N	4022 368 5028
UL	Coil unit UL 12S	4022 368 5048
UL	Coil unit UL 15N	4022 368 5029
UL	Coil unit UL 15S	4022 368 5049
UL	Magnet yoke UL 126 mm	4022 368 5021
UL	Magnet yoke UL 168 mm	4022 368 5022
UL	Magnet yoke UL 210 mm	4022 368 5023
UL	Magnet yoke UL 546 mm	4022 368 5024
UL	Digital Hall Module UL	4022 368 5145
UXA/UXX series		
UXA/UXX	Coil unit UX 3N	4022 368 5105
UXA/UXX	Coil unit UX 3S FLEX	4022 368 5235
UXA/UXX	Coil unit UX 6N	4022 368 5106
UXA/UXX	Coil unit UX 6S	4022 368 5101
UXA/UXX	Coil unit UX 9N	4022 368 5107
UXA/UXX	Coil unit UX 9S	4022 368 5102
UXA/UXX	Coil unit UX 12N	4022 368 5108
UXA/UXX	Coil unit UX 12S	4022 368 5103
UXA/UXX	Coil unit UX 18N	4022 368 5111
UXA	Magnet yoke UX-A 114 mm	4022 368 5098
UXA	Magnet yoke UX-A 171 mm	4022 368 5093
UXA	Magnet yoke UX-A 456 mm	4022 368 5099
UXX	Magnet yoke UXX 114 mm	4022 368 5215
UXX	Magnet yoke UXX 171 mm	4022 368 5216
UXX	Magnet yoke UXX 456 mm	4022 368 5217
UXA/UXX	Digital Hall Module UX	4022 368 5154

Tecnotion Headquarters

Newton 10
7609 RR Almelo
The Netherlands

Tel. +31 (0)546 536 300
Fax +31 (0)546 536 380
sales@tecnotion.com

Tecnotion N-W Europe

High Tech Systems Park
Building N
Haaksbergerstraat 67
7554 PA Hengelo
P.O. Box 23, 7600 AA Almelo
The Netherlands
Tel. +31 (0)546 536 300
sales@tecnotion.com

Tecnotion D-A-CH

Elsenheimerstraße 59
80687 Munich
Germany

Tel. +49 89 381537-400
Fax +49 89 381537-409
info@tecnotion.de

Tecnotion East Europe

Ul. Ryżowa 49
02-495 Warsaw
Poland

Tel. +48 606 544 046
info@tecnotion.pl

Tecnotion Rep. of Korea

Room #909,
DongJin IT Tower,
30, Sangwon 12-gil
Seongdong-gu
Seoul South Korea

Tel. +82 (0)10 4540 5599
korea@tecnotion.com

Tecnotion USA

200 Broadhollow Rd -
Suite 207
Melville, NY, 11747
United States

Tel. +01 (631) 983-2833
salesusa@tecnotion.com

Tecnotion China

Building 15
369 Lushan Road
SND NEP, Suzhou
China

Tel. +86-512-68760183
sales@tecnotion.com.cn

