

Mounting instructions and tolerances can be found in the torque installation manual. Manuals and 3D CAD files can be downloaded from our website.

## STATOR

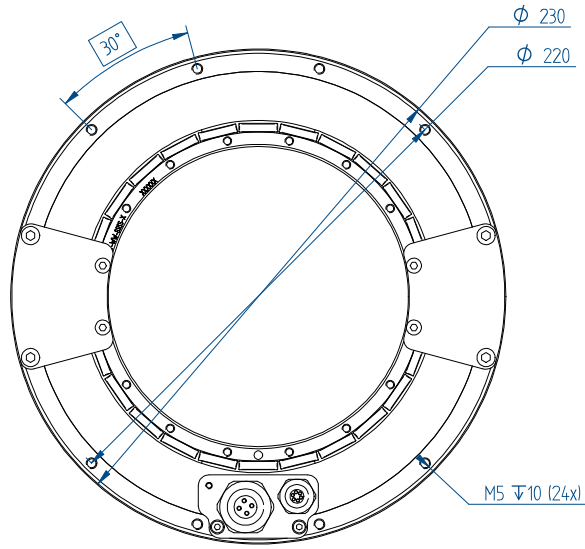

## ROTOR

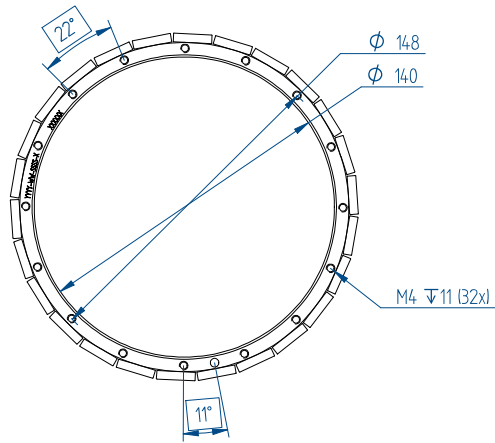

QTL-A 230-65

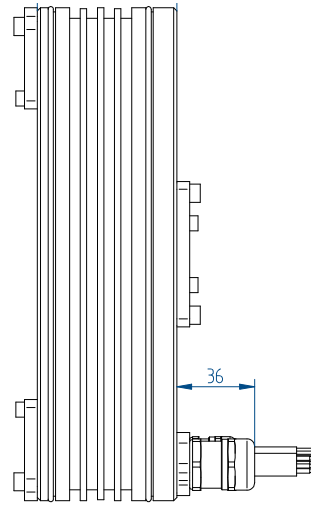

QTL-A 230-85

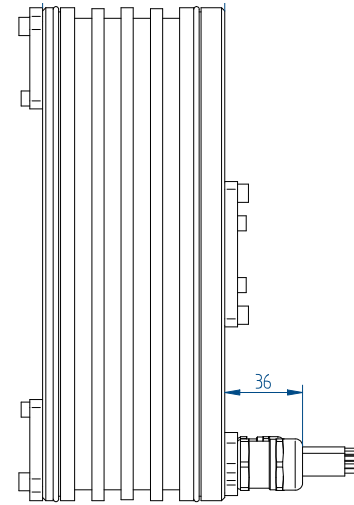

QTL-A 230-105

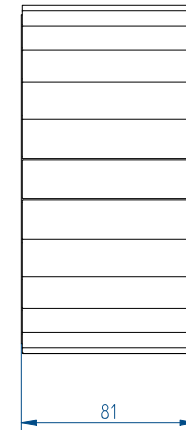
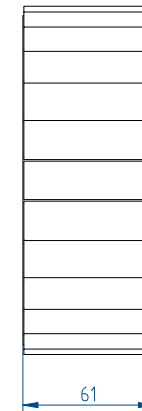
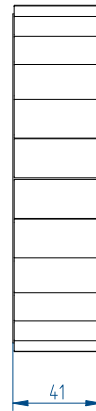
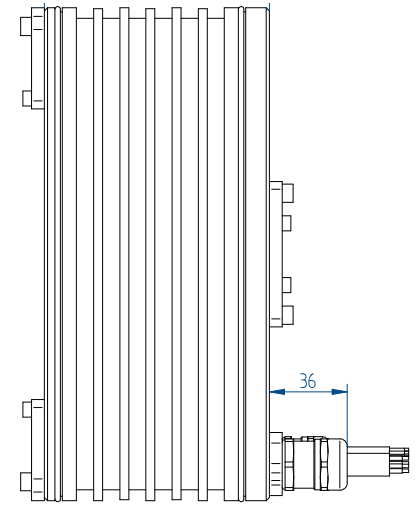

	Parameter	Remarks	Symbol	Unit	QTL-A 230-65	QTL-A 230-85	QTL-A 230-105
Performance	Winding type				N	N	N
	Motortype max. voltage ph-ph	3-phase synchronous		$V_{ac\ rms} (V_{dc})$	480 (680)		
	Ultimate torque @ 20°C/s increase	magnet @ 25°C	$T_u$	Nm	173	259	346
	Peak torque @ 6°C/s increase	magnet @ 25°C	$T_p$	Nm	140	211	281
	Continuous torque	coil @ 100°C	$T_c$	Nm	67	107	147
	Stall torque	coil @ 100°C	$T_s$	Nm	48	76	104
	Maximum speed <sup>(1)</sup>	@ $T_c$ @ 680 Vdc	$n_{max}$	rpm	709	451	321
	Motor torque constant	up to $I_c$	$K_t$	Nm/A <sub>rms</sub>	8.7	13.1	17.5
	Motor constant	coils @ 25°C	$K_m$	(Nm) <sup>2</sup> /W	8.0	13.5	19.2
	Electrical	Ultimate current	magnet @ 25°C	$I_u$	A <sub>rms</sub>	22.0	22.0
Peak current		magnet @ 25 °C	$I_p$	A <sub>rms</sub>	16.9	16.9	16.9
Maximum continuous current <sup>(2)</sup>		coils @ 100°C	$I_c$	A <sub>rms</sub>	7.69	8.16	8.42
Stall current <sup>(2)</sup>		coils @ 100°C	$I_s$	A <sub>rms</sub>	5.44	5.77	5.95
Back EMF phase-phase <sub>peak</sub>			$K_e$	V/krpm	747	1121	1494
Back EMF phase-phase <sub>RMS</sub>			$K_e$	V/krpm	528	793	1057
Coil resistance per phase		coils @ 25°C ex. cable	R	Ω	3.18	4.25	5.31
Coil induction per phase		$l < 0.6 l_p$	L	mH	16.0	22.3	28.7
Electrical time constant			$\tau_e$	ms	5.0	5.3	5.4
Poles			$N_{mgn}$	nr	26	26	26
Thermal	Continuous power loss	coils @ 100°C	$P_c$	W	735	1102	1469
	Thermal resistance <sup>(3)</sup>	coils to mount. sfc.	$R_{th}$	°C/W	0.109	0.073	0.054
	Thermal time constant		$\tau_{th}$	s	49	44	41
	Water cooling flow	for $\Delta T=3K$	$\Phi_w$	l/min	3.5	5.3	7.0
	Water Cooling pressure drop	order of magnitude	$\Delta P_w$	bar	0.7	1.0	1.5
	Temperature cut-off / sensor				PTC 1kΩ (3x) / PT1000 (3x)		
Mechanical	Stator OD		$OD_s$	mm	230		
	Rotor ID		$ID_R$	mm	140		
	Motor height		$H_{motor}$	mm	65	85	105
	Lamination stack height		$H_{arm}$	mm	40	60	80
	Rotor inertia		$J_R$	kg*m <sup>2</sup>	0.009	0.014	0.019
	Stator mass	excluding cables	$M_s$	kg	5.2	7.2	9.0
	Rotor mass		$M_R$	kg	1.6	2.4	3.2
	Total mass	excluding cables	$M_T$	kg	6.8	9.6	12.2
	Cable mass	all cables	m	g	500		
	Cable type (power)	length 2 m	d	mm (AWG)	10.6 (13)		
Cable type (sensor)	length 2 m	d	mm (AWG)	6.4 (25)			



QTL 230 series, with a height of 85 mm

All specifications ±0%

1. Actual values depend on bus voltage. Please check the T/n diagram in our manual or online simulation tool.
2. These values are only applicable when the mounting surface is at 20°C and the motor is driven at maximum continuous current. If these values differ in your application, please check our simulation tool or manual.
3. R<sub>th</sub> based on given water flow and pressure.