

Mounting instructions and tolerances can be found in the torque installation manual. Manuals and 3D CAD files can be downloaded from our website.

STATOR

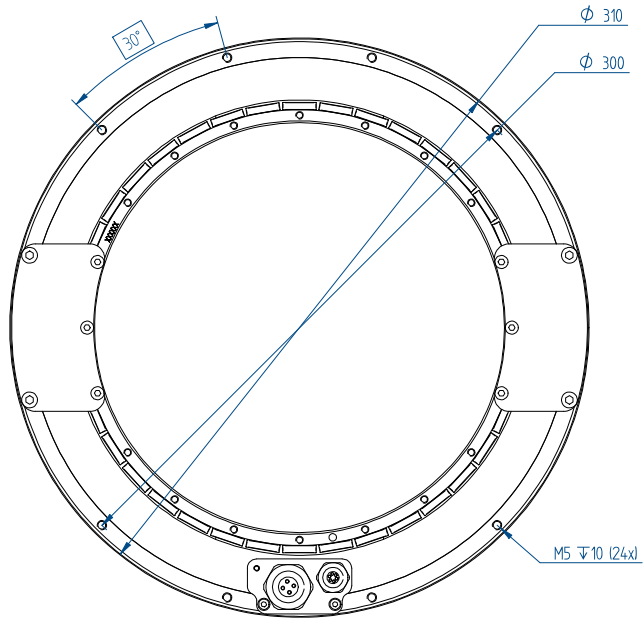

ROTOR

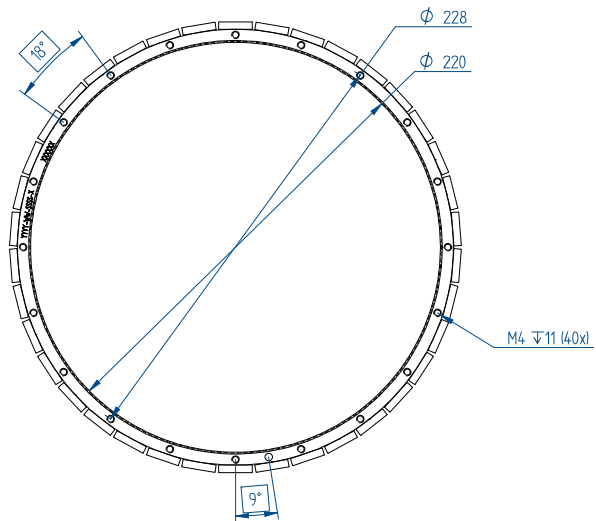

QTL-A 310-65

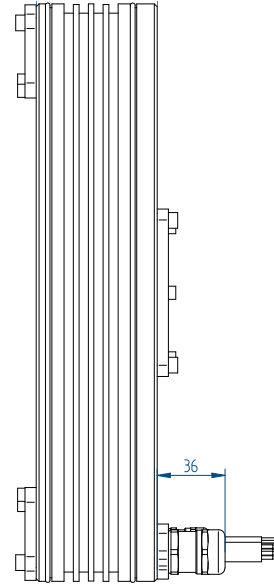

QTL-A 310-85

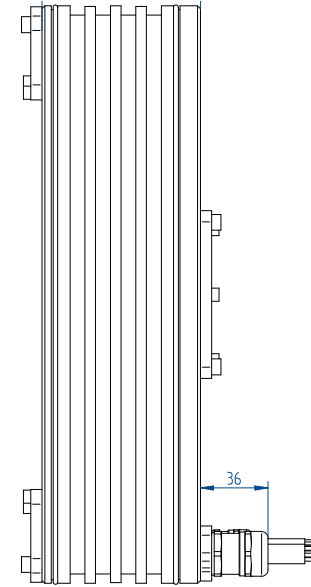

QTL-A 310-105

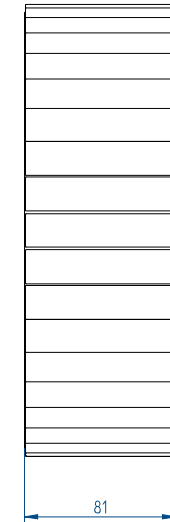
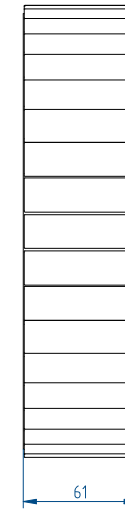
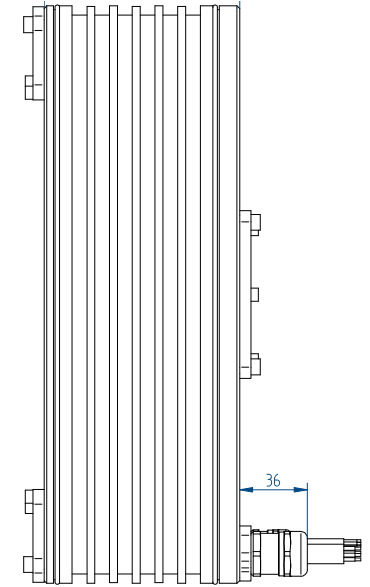

©2019 Tecnotion BV - All rights reserved - The contents of this document are subject to change without prior notice.

	Parameter	Remarks	Symbol	Unit	QTL-A 310-65	QTL-A 310-85	QTL-A 310-105
Performance	Winding type				N	N	N
	Motor type max. voltage ph-ph	3-phase synchronous		$V_{ac,rms} (V_{dc})$	480 (680)		
	Ultimate torque @ 20°C/s increase	magnet @ 25°C	T_u	Nm	389	583	778
	Peak torque @ 6°C/s increase	magnet @ 25°C	T_p	Nm	316	474	632
	Continuous torque	coil @ 100°C	T_c	Nm	151	241	331
	Stall torque	coil @ 100°C	T_s	Nm	107	170	234
	Maximum speed ⁽¹⁾	@ T_c @ 680 Vdc	n_{max}	rpm	298	182	124
	Motor torque constant	up to I_c	K_t	Nm/A _{rms}	19.7	29.5	39.3
	Motor constant	coils @ 25°C	K_m	(Nm) ² /W	27.0	45.5	64.7
	Electrical	Ultimate current	magnet @ 25°C	I_u	A _{rms}	22.0	22.0
Peak current		magnet @ 25°C	I_p	A _{rms}	16.9	16.9	16.9
Maximum continuous current ⁽²⁾		coils @ 100°C	I_c	A _{rms}	7.70	8.16	8.42
Stall current ⁽²⁾		coils @ 100°C	I_s	A _{rms}	5.44	5.77	5.96
Back EMF phase-phase _{peak}			K_e	V/krpm	1681	2521	3362
Back EMF phase-phase _{RMS}			K_e	V/krpm	1189	1783	2377
Coil resistance per phase		coils @ 25°C ex. cable	R	Ω	4.77	6.37	7.96
Coil induction per phase		$l < 0.6 l_p$	L	mH	23.9	34.7	45.5
Electrical time constant			τ_e	ms	5.0	5.5	5.7
Poles			N_{mgn}	nr	38	38	38
Thermal	Continuous power loss	coils @ 100°C	P_c	W	1102	1653	2204
	Thermal resistance ⁽³⁾	coils to mount. sfc.	R_{th}	°C/W	0.073	0.048	0.036
	Thermal time constant		τ_{th}	s	49	44	41
	Water cooling flow	for $\Delta T=3K$	Φ_w	l/min	5.3	7.9	10.5
	Water cooling pressure drop	order of magnitude	ΔP_w	bar	1.0	1.4	2.0
	Temperature cut-off / sensor				PTC 1kΩ (3x) / PT1000 (3x)		
Mechanical	Stator OD		OD_s	mm	310		
	Rotor ID		ID_R	mm	220		
	Motor height		H_{motor}	mm	65	85	105
	Lamination stack height		H_{arm}	mm	40	60	80
	Rotor inertia		J_R	kg*m ²	0.031	0.046	0.061
	Stator mass	excluding cables	M_s	kg	7.4	10.1	12.9
	Rotor mass		M_R	kg	2.3	3.5	4.7
	Total mass	excluding cables	M_T	kg	9.7	13.6	17.6
	Cable mass	all cables	m	g	500		
	Cable type (power)	length 2 m	d	mm (AWG)	10.6 (13)		
Cable type (sensor)	length 2 m	d	mm (AWG)	6.4 (25)			



QTL 310 series, with a height of 85 mm

All specifications ±0%

1. Actual values depend on bus voltage. Please check the T/n diagram in our manual or online simulation tool.
2. These values are only applicable when the mounting surface is at 20°C and the motor is driven at maximum continuous current. If these values differ in your application, please check our simulation tool or manual.
3. R_{th} based on given water flow and pressure.